

VISVESVARAYA TECHNOLOGICAL UNIVERSITY, BELGAUM



A Project Report On

“ANALYSING RS232 PROTOCOL USING USB LOGIC ANALYZER” (SPONSORED BY KSCST, BANGALORE)

A dissertation submitted to the Department of *Instrumentation Technology* of Visvesvaraya Technological University, in partial fulfillment for the Award of Degree of Bachelor of Engineering during the academic year 2009-2010.

PROJECT ASSOCIATES

1. SOWMYA.P	3VC06IT009
2. DEEPIKA.G	3VC06IT003
3. RASHMI.B.M	3VC06IT012
4. RAGHAVENDRA ACHAR	3VC04IT402

PRINCIPAL

Dr. H. MAHABALESHWARA M.E Ph.d

Under the Guidance of
Ms. GAYATHRI B.E(M.TECH)

Project Co-ordinator
Mr. KOTRESH S M.TECH

Head of the Department
Mrs. RAKHEE PATIL M.E

RAO BAHADHUR Y. MAHABALESWARAPPA ENGINEERING COLLEGE
[FORMERLY VIJAYANAGAR ENGINEERING COLLEGE]
DEPARTMENT OF INSTRUMENTATION TECHNOLOGY
BELLARY-583104

ABSTRACT

USB LOGIC ANALYZER

In the current world lot of investment is done in the field of research and development to come up with day to day products that improve the standard of living. One of the major requirements for such development industries is availability of Test equipment. Many companies are heavily involved with the production of such test equipments. Even though the requirement of such devices is large, the cost of these equipments is very high. Our project aims at design a Logic Analyzer that is of low cost and high level of reliability such that it can be affordable by Small Scale Industries and hobbyists. Along with this we aim to provide a better solution for analyzing protocols such as RS232,CAN,I2C,SPI (only RS232 is considered), using the same hardware.

The Universal Serial Bus (USB) was developed and is maintained by a group of companies forming the USB Implementers Forum (USB-IF). Initially developed to replace such fragmented and slow connection interfaces as the parallel and serial ports traditionally used to connect peripherals to PCs, USB has rapidly established itself as the interface of choice for peripherals by providing inexpensive ease of use and high speed throughput. Due to the already said advantages we are using the USB protocol for the purpose of Real Time Data Acquisition.

The block diagram implementation of our project is as shown below.

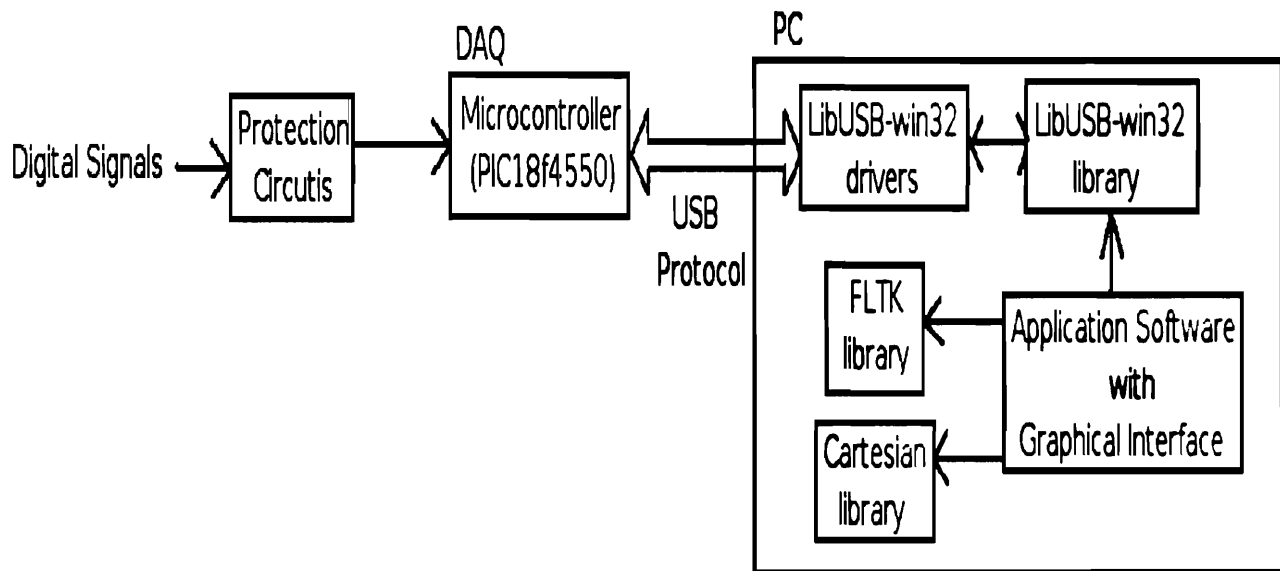

- Digital Signals are the Signals acquired from the hardware which is under test. The signal logic level can either be TTL (5v) or CMOS (3.3v) with 0's and 1's.
- Protection Circuits are used to protect the hardware from being damaged due to incoming signals. These circuits are responsible for maintaining proper voltage level while data is read by the microcontroller.
- The main purpose of the Microcontroller (PIC18F4550) block is for Data Acquisition (DAQ). It reads the digital signal level and puts it into a buffer for USB data transmission.
- PIC18F4550 has the necessary interface to perform USB Protocol operations. The necessary control signals for the DAQ are generated by the PC and transmitted using the USB protocol.

The analysis software are all implemented in PC. It consists of the following blocks

- LibUSB-win32 drivers : this consists of the drivers used to generate the necessary protocol for controlling the USB device.
- LibUSB-win32 library : this is a library that has all the necessary functions that are used to communicate with the USB device using the LibUSB-win32 driver.

- **FLTK library** : this is a library which provides the necessary functions for generating Graphical User Interface (GUI). With the help of this library we can make the application more user friendly.

- **Cartesian library** : this is a library that provides with the necessary plotting functions required to visualize the incoming data from the DAQ. It is with the help of this library that the waveforms of the incoming data is generated.

The Application software, with the help of all the above libraries, gives a interface that is user friendly with proper plotting for visualization of data.

As a conclusion we would say that implementing such a project would provide the development community with a low cost and very stable type of test equipment. Further more additions to the same project can replace the entire test equipment available in any lab.