

# Essays on Bangalore

**VOL. 4**

*Editors*

---

*Vinod Vyasulu*

---

*Amulya Kumar N. Reddy*

---



**K S C S T**

**ESSAYS ON BANGALORE**  
**VOL. 4**

**Convenors**  
**Vinod Vyasulu**  
**Amulya Kumar N. Reddy**

**Karnataka State Council for Science and Technology**  
**Indian Institute of Science, Bangalore-560 012**

*First Impression–November 1985*

*Published by :*

**Karnataka State Council for  
Science and Technology  
Indian Institute of Science,  
Bangalore–560 012**

*Cover Designed by :*

**MARCO, Bangalore**

*Printed at :*

**PRABHA PRINTERS & PUBLISHERS  
150, Coconut Avenue Road  
Malleswaram, BANGALORE–560 003**

## **C O N T E N T S**

	<b>Page</b>
<b>Preface</b>	<b>i</b>
<b>Acknowledgement</b>	<b>iii</b>
<b>The Food Supply System of Bangalore</b> – <i>Sukumar Muralidharan</i>	<b>1</b>
<b>Supply, Distribution and Consumption of Milk in Bangalore</b> – <i>Thomas P. Benjamin</i>	<b>21</b>
<b>Elementary Education in Bangalore City</b> – <i>S. Nayana Tara</i>	<b>37</b>
<b>Bangalore City's Water Supply – A Study and Analysis</b> – <i>D. K. Subramanian</i>	<b>51</b>

## PREFACE

Bangalore was the fastest growing city in India in the 1970's. But, before this fact become generally known, two scholars had set out to study the structure of this emerging metropolis. Prof. V.L.S. Prakasa Rao and V.K. Tewari undertook a meticulous study that yeilded a veritable gold mine of data. <sup>1</sup> This study has been the main inspiration for the essays that follow, which are grouped into four parts.

As an earlier review pointed out, there was a great deal more that could have been gleaned from the data provided by Professor Prakasa Rao and Tewari. This is well brought out in the study of slums in Bangalore by Dr. H. Ramachandran. Also, if the data was to be of immediate use to the Policy maker, there were several other aspects that needed examination. The essays that follow may not succeed in completing this task, but they have succeeded in taking a small step forward. Thus, the study of the late Dr. Ramachandra Rao has many suggestions that will help rid the city of the mosquito menace. The study of firewood and charcoal by Prof. Amulya Reddy and Mr. Sudhakar Reddy also pose sharply the choices that face policy makers. The study of Dr. Anna Mani on Bangalore's climate makes certain points about architectural styles that will need to be taken into accounts in any future master plan for the orderly growth of Bangalore. This is true of the points in many of the other essays.

There are also areas of non-clarity.

Dr. Ramachandra Rao would like a reduction in the number of tanks in Bangalore to control mosquitoes; Dr. D. K. Subramanian would like more tanks to harvest rain to augment the city's water supply. These are areas that require further study.

Policy makers have been concerned with the growth of Bangalore. In this context, one should be careful in drawing policy implications from these essays. While several authors suggest ways of improving quality of life in the city, and even suggest certain levels of investment, it does not follow that these investments must necessarily be made. A hundred crores spent on Bangalore has to be seen against a hundred crores spent on making life better in other cities in Karnataka. If Raichur, Mysore, Hubli, Mangalore and so on become more attractive, it may be the best way of slowing down the growth of Bangalore. An investment on cities should also be assessed against the alternative of improving the quality of life in villages. This is an exercise that these essays have not undertaken.

---

1. *V. L. S. Prakasa Rao and V. K. Tewari, 'The Structure of an Indian Metropolis' : A study of Bangalore', Allied Publications, New Delhi, 1980.*

It has also to be recognized that there are other factors that would influence urban growth in Karnataka. If, for instance, the railways were to construct broad-gauge lines from Mysore to Miraj, from Mangalore, Hassan, Shimoga to Raichur and Gulbarga, it would make a very basic difference to the entire pattern of economic development of Karnataka. A great deal of the more positive aspects of development in neighbouring Andhra Pradesh can be attributed to a good rail network.

In short, these essays show how much more needs to be done to develop a coherent set of policies for urban growth in Karnataka. If they result in stimulating further work, they will have served their purpose.

**Vinod Vyasulu**  
**Amulya Kumar N. Reddy**

## **ACKNOWLEDGEMENTS**

We thank the Karnataka State Council for Science and Technology for sponsoring the project on 'Bangalore as an Urban Ecosystem'. Apart from generous financial and excellent administrative support, the researchers were given complete freedom.

We would also like to thank the members of the Working Group constituted by the KSCST to guide the project, for encouragement and support in our work.

We were fortunate in having the support of several scholars whose papers appear in these volumes. The encouragement given by their institution—the Indian Institute of Science, the Institute for Social and Economic Change and the Indian Institute of Management, Bangalore and so on are gratefully acknowledged.

We thank the several young project assistants who worked hard and cheerfully. They are : Shri B. Sudhakar Reddy, Ms. Tara N. Srinivas, Shri S. Ramakrishna, Shri Ashok Kumar Kattimani, Ms. Fathima Nusrat Tehan, Dr. S.G. Sathyanarayana, Shri Sukumar Muralidharan, Shri K. Arun, Shri P. N. Swamy, Ms. V. S. Vathsala, and Ms. Shuba Abraham.

The participants in the two seminars held in June 1983 and May 1984 made many useful comments which the authors have taken into account in revising their papers.

Of course, errors and opinions are those of the authors, the organization is the responsibility of the Convenors, and the credit should go to the KSCST.

**Vinod Vyasulu**  
**Amulya Kumar N. Reddy**  
(Convenors)

## **THE FOOD SUPPLY SYSTEM OF BANGALORE**

**SUKUMAR MURALIDHARAN**

**1.0 Three sectors of foodgrains supply to Bangalore City may be identified :**

- (i) The public distribution system**
- (ii) The private organised-regulated market committee yard (RMC) sector**
- (iii) The private organised (non-RMC) sector**

**1.1 The Commodities handled in the respective sectors are as detailed below :**

- (i) Public distribution—rice, wheat and wheat products**
- (ii) RMC sector—rice, ragi**
- (iii) Non-RMC sector—wheat, jowar, bajra and other cereals.**

The RMC sector is not fully exhaustive as far as arrivals of rice and ragi are concerned, despite an official notification to that effect. Hence, arrivals of rice and ragi outside the RMC sector would have to be allowed for, under a hypothetical private, “non organised” sector.

**2.0 Data on the quantities of commodities handled by the respective sectors is somewhat inadequate. Data is available on the arrivals of ragi in the RMC yard between 1971-72 and 1981-82, and of rice between 1979-80 and 1981-82. These are presented in Appendix I. It will be seen that arrivals of ragi have maintained a degree of consistency over the years in question, whereas those of rice have shown some inexplicably large fluctuations. The authenticity of data is somewhat suspect since between 1979-80 and 1980-81, we have a situation of arrivals of rice falling almost fourfold in quantity, while multiplying three fold in value. Unit value of rice must therefore have increased by almost twelve fold in this one year—a conclusion which would seem rather difficult to accept. However, if one is to accept the data on ragi as authentic, then one could draw the conclusion that despite the rapid growth in the city population between 1971-72 and 1981-82, consumption of this inferior cereal has not increased. Ofcourse this conclusion cannot be advanced with any conviction until arrivals of ragi outside the RMC yard are monitored. However, data on consumption expenditure gathered under the 32nd round of the National Sample Survey may be used as a cross-check. This data is available with the Indian Statistical Institute, Bangalore, but is presently not accessible.**

**2.1 Data on the allotment and offtake of select foodgrains and food products, through the public distribution system is presented in Appendix II. Rice is the only commodity handled by both the RMC and the PD systems, and it will be seen that the quantity handled by the PD system is one order of magnitude less than the RMC sector.**

2.2 In the non-RMC sector, there is no comparable, organised source of data available. An extensive survey would have to be conducted before a reasonable picture can be constructed.

3.0 The delivery and distribution system for the RMC sector may be briefly described thus : "Commission agents" constitute the central nodes of commodity flow. Purchases of rice are made from the millers and purchases of ragi from the growers. The term "commission agent" indicates that these people are acting on behalf of the growers/millers in the urban areas, but the truth perhaps is that they enjoy a far larger degree of market power than the agriculturists because of their control over the channels of trade, and their superior degree of commercial organisation.

The usual *modus operandi* is for growers and millers to canvas orders from the commission agents just before the growing season : samples are sent down. Orders are then placed, and deliveries are made, almost exclusively by trucks. Transport costs are borne by the commission agents. From the wholesaler, the commodity goes by cash or credit transaction to the semi-wholesaler and/or the retailer.

Transactions are made by the commission agents at the primary markets. The most important primary sources of ragi for Bangalore city are Davangere, Hosadurga and Holakarai in Chitradurga district, and Haveri in Dharawad district. With regard to rice, 40-50% of the arrivals in Bangalore city are from the Nellore, west Godavari and Telangana areas of Andra Pradesh. These are predominantly the fine and superfine varieties. From within Karnataka, the most important primary sources are Raichur, Gangavathi, Davanagere, Bellary and Shimoga. Enquiries with rice traders have revealed that these markets contribute predominantly the common (medium & coarse) varieties of rice.

Peak arrivals of ragi are in the months of February to April ; while for rice, the months of June and December are the most important. Official data however do not seem to reflect any such trend. Table-1 records, from an available month-wise breakup of ragi arrivals for the years 1978-1981, the three months of the year that registered the highest arrivals. The next column presents the months of the year that recorded the lowest retail prices of the commodity. There does not appear to be any discernable correlation between the quanta of arrivals in the city in any particular month and the level of prices.

An Interpretation of price trends and correlation with the quanta of arrivals in the market would require a better understanding of the market behaviour of the wholesale merchants. The ability of the wholesalers to influence price trends is obviously a function of their market power, and this is to be at least partly understood in terms of their power to buy up stocks at harvest time, and to store it up to meet the demand over the year, which one may take to be a constant figure, independent of seasonal influences. Available data does not permit a study of this nature at this juncture.

The infrastructure for the marketing of food products was built up by the State Government under a World Bank supported scheme in the 1970's. As a price for the provision of these facilities, the Agricultural Products Marketing Committee in each district charges a "market cess" amounting to two per cent of the turnover. this levy was recently a bone of contention between the Government and the traders, with the traders threatening a "strike" in protest. The Government, arguing that the burden of the levy was borne ultimately by the consumer, and that the proceeds were essential for the maintenance and upkeep of the market yards, refused to withdraw the levy. The issue finally just seemed to loose steam, and the traders' movement petered out. But this is just the least of the problems that have seemed to perpetually dog the urban food supply system in recent times.

3.1 The public distribution system may be schematically represented as in Figure 1.

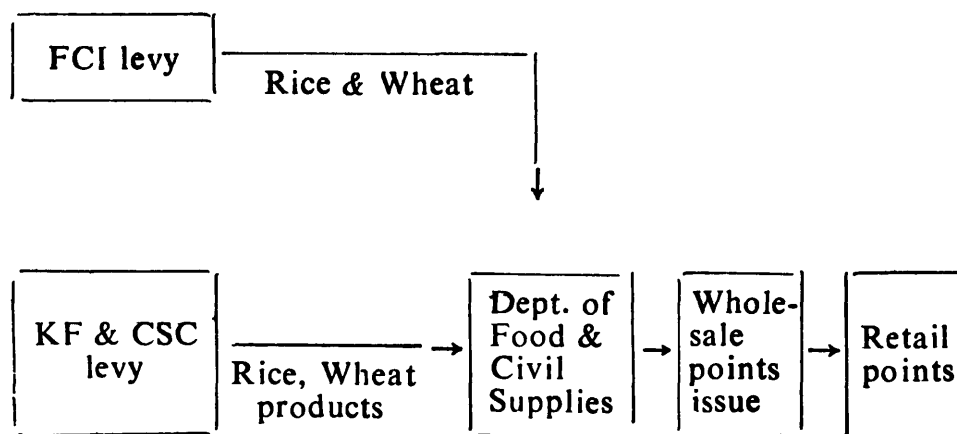

The two sources of supply are the Food Corporation of India levy and the Karnataka Food and Civil Supplies Corporation levy. The Department of Food and Civil Supplies is the apex body for distribution through the rationing system. The Department allocates grain between the wholesale issue points, of which there are in all 21 in the city, -12 under the KF & CSC and 9 under various co-operative societies. The fair price depots constitute the next stage in the hierarchy—retail outlets. These have hitherto been largely under private ownership, though a recent notification seeks to nationalise these by January 1984. A geographical breakup of these fair price depots, of the number of ration cards handled by each zone, and the number of beneficiaries is given in Appendix III. In Appendix IV we have the data on types of FDD's, types of control and geographical distribution across the four ranges of the city. At the level of disaggregation available, there does not appear to be any discernible design or pattern in the distribution of these FFD's. However, it will be observed that the Central Range has far fewer outlets and beneficiaries compared to the others. It will also be noticed that all the retail outlets maintained by industries are in the Northern and Eastern Ranges which one would expect, are areas of relatively heavy working class concentration. It would be a most important exercise to map the various wholesale and retail points in the city.

the commodities handled by them, and to correlate the volume and structure of transactions with the population characteristics (such as income, occupation, etc.) in the various areas. The Prakasarao/Tewari survey that collected data on selected socio-economic indicators across the various zones may provide important indications in this direction.

Despite providing only a small fraction of the food requirements of the city, the public distribution system has attracted a great deal of public attention in recent times. This is because of the externally contentious issues of fixing levy and issue prices for the various grains, and the nature of the delicate political balance to be maintained through food pricing policy. Recent developments indicate that between the agriculturist and the consumer, the government has been tending to favour the former so far as price policy is concerned. Though one way of off-setting the pressure induced by higher levy prices is through a food subsidy, this policy has also been disfavoured, since it leads to turgent budgetary dificits at a time when State finances are not in very good shape. A brief recapitulation of certain salient-features of the government's food pricing policy may now be in order.

In rice, the policy of mill-point levy is usually in force. Rice millers are expected to sell 40 to 50 percent of the total paddy purchased by them under the trading account to the KF & CSC. One could well ask then, given this high percentage, what accounts for the insignificantly small percentage of rice transactions going through the PDS. The answer is that the entire procedure can be circumvented by a simple accounting device on the part of the rice miller. The power of the rice mill lobby is considerable, and in August 1982, the then Government took a decision to switch over from mill-point levy to growers' levy. The decision was ostensibly prompted by the "wishes of the people", who had disfavoured the mill-point levy despite it being easier to operate from the point of view of the Government. The administrative machinery required to make a growers' levy operational was seen to be quite elaborate. Yet there was no attempt to compute the costs and the benefits involved in the exercise, and to arrive at an estimate of the implicit subsidy that would be borne by the state if the consumer was to be spared the additional cost burden. This being the case, it came as no surprise when the new administration in January 1983, reverted to the mill-point levy.

The levy prices in effect through the 1982-83 season for rice were Rs. 206.75, Rs. 202.75, and Rs. 194.75 per quintal, respectively for superfine, fine and medium varieties, the prices for the corresponding varieties of paddy were Rs. 130, Rs. 126 and Rs. 122 per quintal, respectively. Simultaneously, retail prices were Rs. 2.45, Rs. 2.10 and Rs. 2.00 per kg for the three varieties. In January 1983, the prices were cut to Rs. 2.10, Rs. 2.00 and Rs. 1.90 per kg respectively. With the old ratio of levy prices prevailing, this would have meant an additional financial burden upto the government an insupportable one in the context of a general upward pressure on the levy price. By August 1983, the compulsions were strong enough to prompt a revision

of the retail price structure to Rs. 2.45, Rs. 2.30 and Rs. 1.90 for the three grades of rice. This has been followed, in November 1983, by a decision to raise the levy price of rice by about Rs. 12 and that of paddy by about Rs. 10/- per quintal, across all varieties.

Apart from the constant revision of prices, there are other signs of strains manifest in the recent policy decision to "take over" all private fair price depots. It is not yet clear whether this would mean an outright nationalisation, or the establishment of consumer co-operatives (with government nominees on their boards or without). The matter is in any case under disputation at the moment, and a reasonably clear picture could only emerge over the next two months. However, if the motivations behind this policy decision are genuinely as the government avers, then this is perhaps a signal that there is today a compulsion on the part of the government, caught in a bind between the agriculturists and the consumers, to eliminate possible leakages from the public distribution system. Under the old system the retailers' margins were specified by policy. The success of the new system will rest in ensuring that the costs of maintenance of the distribution infrastructure do not exceed these prescribed margins on every unit of commodity transacted. Failing this we will either have additional financial burden upon the state or an extra burden of price upon the consumer.

Similar developments are taking place in the distribution of wheat products through the PDS. The KF & CSC does not procure any wheat. The wheat products channeled through the KF & CSC are the output of roller flour mills, which obtain wheat from the FCI against allotments made by the Director of F and CS, Government of Karnataka. The millers' margin in this case is specified by policy. Of late there has been a decision to slash this from Rs. 23 to Rs. 16.50 per quintal. The prices of maida and soji are hence expected to fall. However, the final outcome of this measure too is difficult to foresee right now.

Procurement operations in wheat are performed by the FCI, and even here, there have been tendencies in the recent past towards rapid price escalation. For instance, the average annual increase in the procurement price during the three years from 1980-81 to 1982-83 has been over Rs. 11 per quintal, while in the preceding four years period it was only Rs. 3. The issue price has changed correspondingly. However, the price levels of wheat are part of a larger set of considerations, and under the authority of a central agency. Policy decisions at the state level, if not ruled out altogether, could not be expected to have more than a very marginal impact. Consideration of this question could therefore be deferred until a larger study is undertaken.

Since the public distribution system is constantly under public scrutiny, it is important to understand the function it plays within the urban food distribution system. It is at present not possible to list the correlates of grain consumption patterns in terms of income group, occupational status, and other such parameters.

Perhaps this information can be abstracted from the Prakasrao/Tewari survey (1974) and the Karnataka Dairy Development Corporation's survey (1980). Given a knowledge of consumption patterns across various income and occupational groups, we could perhaps identify the groups that would be vulnerable to adverse fluctuations in the price level. From an available month-wise series of retail prices of select food grains, summarily shown in Table 2, we may note that though certain commodities have shown large fluctuations in value at certain times, the overall variation is not much, as evinced by the computed values of the standard deviations. However, the various pulls and pressures within the PDS probably indicate that it has an important role to play as a buffer even against fluctuations of such small magnitude.

Apart from the relative smallness of the PDS, one could point out other reasons why it may not be an effective safety valve against adverse price changes in future. This arises from the simple fact that it is precisely at times of rapid price escalation that the levy procedure becomes increasingly difficult, since the inducement to divert grain to the non-levy channel is especially strong. Thus if the government is to offer a correspondingly strong inducement, either the financial burden they will have to bear would be higher, or else the price rice would have to be passed on to the consumer. The former alternative is beginning to be increasingly disfavoured in an overall climate of financial stringency, and the latter alternative would defeat the very purpose of the public distribution system. The changes currently being introduced in the PDS would therefore be worth watching closely over the coming months.

4.0. In this concluding section, a brief examination of some key features of the system of economic linkages through which the urban food supply system functions. From the farm to the urban retail outlet, the food passes through a hierarchy of stages, with definite price relatives prevailing at every stage. Data are available on farm harvest prices for agricultural commodities, district-wise, between 1973-74 and 1981-82. Further wholesale price data (i.e. price paid by the wholesale dealer to procure the commodity, hence wholesale purchase price and not sales price) is also available between 1969 and 1980, both as a weighted average over all districts and, for Bangalore district alone. These are presented respectively in Appendices VI and V.

It will be seen that wholesale price in Bangalore District are, as a rule, higher than over the entire state. The reason probably is that the state average gives due weightage to the primary producing centres where one may expect wholesale prices to be lower due to the absence of a transportation component. This is perhaps borne out by the fact that the differential between the Bangalore district figure and the state weighted average is generally less for the case of ragi than for other grains. Keeping in view the fact that Bangalore City is situated in the midst of a ragi belt this becomes understandable.

Given the farm harvest, the wholesale and the retail prices, it should be possible to calculate the price spread effect, i.e., the distribution of grains across various interest groups in the urban food-grains trade. Unfortunately, this becomes compli

cated for the following reasons : firstly, the reporting year used for the farm harvest price series is the year ending in June, whereas the wholesale price series uses the calendar year. Secondly, the multiplicity of varieties of grain listed in the wholesale price index is not mirrored in the farm harvest price series. Thirdly the farm harvested price series gives only the price prevailing during the harvest period. Not all the grain need be transacted at that period. Some could be stored up at the farm point itself, and used for speculative purpose in the off-season. On the other hand, the larger part of the grain may be sold, and be stocked up at a higher stage in the distributive hierarchy. These are imponderable issues given the present state of knowledge and must wait upon a larger study for their resolution. However, given all these limitations, we can still calculate the differential between wholesale and retail price (i.e., wholesalers' and retailer's margins) for two varieties of rice--medium and coarse, for ragi and for jowar. Further, by assuming the reporting year 1973-74 to equivalent to the calendar year 1974, in a transactionary sense, we can calculate the margin between wholesale and farm harvest prices. These results are presented respectively in Tables 3 and 4. A brief examination of these is now done.

Table 3 presents the sum of wholesale and retail margins on four foodgrains. It will be seen that there is no pronounced tendency within the time period under consideration. There have been large fluctuations in all four series most so far the case of jowar. We find the series for ragi showing relatively the greatest degree of stability. Between the two varieties of rice, neither has shown a tendency towards being higher than the other. The wholesale trade in rice is not a specialised one : single concerns usually deal in various qualities of rice. It would be worth investigating into the implications this would have upon market behaviour of the wholesalers, and also how these are reflected in the price margin.

The two lower cereals jowar and ragi, as has been said, show respectively the largest fluctuations in margins and the highest degree of stability. This could be partly at least, due to the proximity of the ragi producing centres relative to the jowar sources, and the consequent effect upon transportation costs. But there are also the consumer preference factors such as substitutability and so on which are of obvious relevance.

The margin between the wholesale and farm harvest prices in respect of ragi does not display any kind of tendency, Summing the two margins for this cereal, we obtain the series shown in table 5. Again, there is no specific design or purpose discernible here.

It would of course be futile to argue that there is actually no design in the entire network of exchange that constitutes the urban food supply system. The design is reflected in the profit maximizing behaviour of the producers, and hinges upon a delicate hierarchy of prices. The city is built above all, on this "smychka" or linkage with the country. The present conjuncture of relations between town and country is marked by symptoms of strain--reflected in the popular imagination

in the shape of farmers' agitations for higher output prices, input subsidies, etc. That this is occurring despite a persistent movement in the terms of trade in favour of agriculture is a sign that perhaps the viability on the entire system of foodgrains delivery and distribution may be in question. In this context, some studies have hypothesised that the number of intermediaries in the foodgrains trade has increased enormously, leading to several "leakages" from the system, and a downward pressure at all levels, perhaps felt most acutely at the lowest level. If this is to account for the very visible disgruntlement among the primary producers then the matter must be investigated in greater depth, and concrete policy and institutional measures evolved to rationalise the system.

TABLE-1

**Month-wise breakup of Ragi Arrivals 1978-1981**

Year	Months (decending order) of peak arrivals of ragi			Months (ascending order) that recorded lowest retail prices of ragi.
1978	1. Oct.	2. Nov.	3. March	May-June, Sept.-Dec.
1979	1. May	2. Jan.	3. June	May — August
1980	1. Mar.	2. Sept.	3. Oct.	Jan. — May
1981	1. Jan.	2. Feb.	3. July	Jan. — July

**TABLE-2**

**Retail Prices of Select Food Commodities Monthwise Averages,  
Standard Deviations and Ranges 1973-1982**

Commodity	Year	Average price	Standard Deviation	Range — peak value-low valve
1	2	3	4	5
Rice-Medium	1973	2.23	0.08	0.80
	1974	2.71	0.08	0.85
	1975	3.08	0.05	0.65
	1976	2.41	0.05	0.70
	1977	2.45	0.01	0.10
	1978	2.26	0.03	0.30
	1979	2.28	0.03	0.20
	1980	2.50	0.02	0.20
	1981	3.13	0.05	0.70
	1982	3.71	0.07	0.50
Rice-Coarse	1973	1.91	0.05	0.80
	1974	2.49	0.07	0.70
	1975	2.79	0.04	0.46
	1976	2.07	0.07	0.80
	1977	2.23	0.02	0.20
	1978	1.90	0.05	0.40
	1979	2.02	0.05	0.40
	1980	2.32	0.02	0.20
	1981	2.79	0.03	0.40
	1982	3.21	0.07	0.50

	1	2	3	4	5
<b>Soji</b>	1973	2.34	0.19	1.70	
	1974	3.87	0.11	1.00	
	1975	3.40	0.07	0.80	
	1976	3.02	0.02	0.20	
	1977	3.36	0.04	0.30	
	1978	3.35	0.03	0.30	
	1979	3.38	0.03	0.30	
	1980	3.55	0.05	0.40	
	1981	4.22	0.08	0.60	
	1982	4.57	0.09	0.90	
<b>Ragi</b>	1973	1.27	0.08	0.90	
	1974	1.66	0.05	0.65	
	1975	1.80	0.06	0.75	
	1976	1.27	0.06	0.65	
	1977	1.53	0.01	0.10	
	1978	1.31	0.05	0.45	
	1979	1.18	0.01	0.05	
	1980	1.46	0.09	0.80	
	1981	2.09	0.03	0.30	
	1982	1.86	0.03	0.40	

1	2	3	4	5
Jowar	1973	1.42	0.03	0.35
	1974	1.70	0.12	1.15
	1975	2.18	0.05	0.80
	1976	1.79	0.02	0.20
	1977	1.84	0.06	0.90
	1978	1.77	0.11	0.90
	1979	1.60	0.00	0.00
	1980	1.82	0.04	0.40
	1981	2.25	0.04	0.40
	1982	2.40	0.00	0.00
Wheat	1973	—	—	—
	1974	—	—	—
	1975	2.32	0.11	1.10
	1976	1.99	0.07	0.70
	1977	1.80	0.09	0.90
	1978	1.87	0.09	0.80
	1979	1.75	0.01	0.10
	1980	1.94	0.04	0.50
	1981	2.53	0.06	0.50
	1982	2.82	0.06	0.40

**Source :** Computed from records maintained at the Indian Institute of Socio-Economic Studies, Bangalore.

TABLE - 3

Wholesalers Margin plus Retailers Margin for selected Foodgrains, 1973-1980 (In Rs. per quintal)

Commodity	Year							
	1973	1974	1975	1976	1977	1978	1979	1980
Rice (Medium)	27.37	32.71	43.21	48.46	42.00	32.56	27.77	31.27
Rice (Coarse)	16.79	38.71	48.17	35.12	40.29	20.42	23.62	43.35
Ragi	2.67	13.96	23.5	12.12	12.33	14.42	17.96	26.25
Jowar	28.75	31.21	82.17	195.83	71.79	79.73	60.58	46.00

TABLE - 4

Wholesale Price Minus Farm Harvest Price for Ragi 1974-1980 (In Rs. per quintal)

Ragi	30.79	1.72	33.03	11.65	19.74	14.53	26.01
------	-------	------	-------	-------	-------	-------	-------

TABLE - 5

Sum of the Two Margins for Ragi

Ragi	44.75	25.22	45.15	23.98	34.16	32.49	52.26
------	-------	-------	-------	-------	-------	-------	-------

APPENDIX - I

**Quantities and values of arrivals of selected foodgrains  
in the Bangalore RMC yard (in quintals, and Rs. in lakhs)**

Year	Ragi		Rice	
	Quantity	Value in Rs.	Quantity	Value in Rs.
1971-72	1,84,052	1,47,24,160	—	—
1972-73	1,80,794	1,98,87,340	—	—
1973-74	1,30,680	1,96,02,000	—	—
1974-75	1,86,470	2,98,35,200	—	—
1975-76	2,02,545	2,43,05,400	—	—
1976-77	3,46,291	4,06,90,295	—	—
1977-78	2,10,919	2,47,92,735	—	—
1978-79	2,61,282	2,47,76,131	—	—
1979-80	2,80,638	2,52,92,835	63,71,147	16,03,71,678
1980-81	2,80,046	3,88,03,917	17,49,873	44,53,73,539
1981-82	2,29,219	5,69,64,405	12,02,945	34,57,37,870

## APPENDIX - II

## Allotment and offtake through PDS of select foodgrains and food products for the year 1981

Sl. No.	Month	Rice		Wheat		Maida		Soji	
		Allotment	Offtake	Allotment	Offtake	Allotment	Offtake	Allotment	Offtake
1.	January	20,530	12,919	1,075	870	1,081	1,436	640	890
2.	February	14,000	10,250	1,075	817	1,300	1,241	893	803
3.	March	10,500	11,472	1,100	1,019	1,518	1,536	900	1,054
4.	April	10,500	10,739	1,000	964	1,673	1,339	838	633
5.	May	10,500	9,889	1,000	926	1,794	1,435	847	816
6.	June	9,950	9,369	1,000	909	2,265	1,268	950	950
7.	July	12,900	11,260	1,000	952	2,265	1,792	950	825
8.	August	11,950	11,330	1,000	954	2,265	1,451	950	825
9.	September	13,000	11,804	1,000	1,046	2,165	1,817	857	857
10.	October	15,000	11,490	925	916	3,110	1,206	1,084	924
11.	November	15,000	12,693	1,125	1,100.3	3,070	1,898	1,130	935
12.	December	15,000	11,267	1,125	1,121.6	2,535	1,750	953	891
		158,830	134,482	12,425	11,594.9				

Source : Department of Food and Civil Supplies, Government of Karnataka.

APPENDIX-III

Sl. No.	Range	No. of Divisions (Corp. Divisions)	No. of FPDs	Number of Ration Cards	Number of Units	Adult Beneficiaries	Child Beneficiaries	Total
1.	South	16	342	1,71,557	21,03,212	9,95,848	1,11,516	11,07,364
2.	North	15	434	2,07,300	24,60,846	11,63,702	1,33,442	12,97,144
3.	East	17	332	1,79,216	22,24,284	,55,564	1,13,156	11,68,720
4.	Central	15	180	75,424	9,67,620	4,59,486	48,648	5,08,134
Total		63	1,288	6,33,497	77,55,964	36,74,600	4,06,762	40,81,362

Source : As in Appendix II

Appendix IV

Sl. No.	Range	Co-operative Societies	Industries	Individuals	SC/ST	KF & CSC	Total
1.	South	47	—	268	17	10	342
2.	North	74	5	324	21	10	434
3.	East	41	7	238	27	19	332
4.	Central	15	—	160	5	—	180
Total		177	12	990	70	39	1288

Source : As in Appendix II.

## APPENDIX - V

## State weighted average

Commodity	1969	1970	1971	1972	1973	1974	1975	1976	1977	1978	1979	1980
Rice (fine)	146.16	133.78	139.83	156.78	211.52	245.23	—	215.78	217.45	213.26	215.23	237.03
Rice (medium)	129.15	117.46	125.15	141.39	189.48	223.60	249.30	189.67	202.75	186.78	189.04	210.65
Rice (coarse)	114.83	101.23	111.96	127.55	172.33	205.24	223.57	166.85	183.27	165.96	155.25	184.21
Wheat (white)	108.61	100.26	105.83	108.88	168.65	231.30	203.39	175.94	179.96	175.15	175.77	192.07
Wheat (red)	—	—	—	—	—	—	—	—	170.53	166.10	170.29	182.01
Wheat (flour)	102.15	99.65	102.42	111.44	160.02	223.41	—	—	163.62	172.00	—	185.91
Jowar (white)	74.73	76.33	84.39	92.93	137.91	152.38	159.19	123.62	127.12	100.09	110.20	128.00
Bajra	69.24	69.09	67.50	77.43	120.46	131.39	139.53	96.22	110.33	97.58	85.86	108.78
Maize	63.92	62.32	62.37	72.71	106.56	135.23	136.44	89.16	107.80	96.77	93.82	110.23
Ragi	76.32	68.22	70.42	77.92	119.63	140.88	145.59	101.67	123.90	100.32	92.70	113.37
<b>B'lore Dist.</b>												
Rice (fine)	160.79	142.33	147.61	161.71	215.63	260.54	—	221.88	231.79	235.63	236.17	243.30
Rice (medium)	135.50	120.90	136.96	152.00	195.63	288.29	264.79	192.54	203.00	193.44	200.23	218.73
Rice (coarse)	118.72	103.02	126.63	141.00	174.21	210.29	230.83	171.88	182.71	169.58	178.38	188.65
Wheat (white)	123.70	111.97	126.09	114.20	154.93	246.50	220.83	176.92	197.18	185.75	189.06	183.53
Wheat (red)	—	—	—	—	—	—	—	193.75	202.42	187.62	176.59	180.00
Wheat (flour)	86.64	90.31	95.54	109.79	118.13	216.43	—	—	—	217.00	—	167.58
Jowar (white)	72.27	67.88	70.13	74.08	113.25	138.79	135.83	106.17	112.21	97.27	99.42	136.00
Bajra	72.98	67.29	66.31	76.67	134.08	134.38	161.04	106.67	112.28	103.17	94.79	113.80
Maize	65.94	61.88	64.14	72.71	115.58	143.96	133.63	97.25	111.13	105.40	101.92	128.07
Ragi	78.98	71.60	74.92	80.67	124.33	152.04	156.50	114.88	140.67	116.58	100.04	119.75

APPENDIX – VI

**Farm harvest prices for Agricultural Commodities**

(Source : Bureau of Economics and Statistics, Bangalore)

COMMODITY : Paddy	(Rs. per quintal)								
District	1973-74	1974-75	1975-76	1976-77	1977-78	1978-79	1979-80	1980-81	1981-82
1. Bangalore	132.68	150.17	101.40	122.70	100.81	97.41	103.11	132.72	150.67
2. Belgaum	113.18	127.28	120.12	114.81	105.10	87.70	93.24	106.53	126.23
3. Bellary	88.64	143.10	111.53	108.38	99.39	72.73	88.00	119.13	140.00
4. Bidar	—	—	—	—	—	—	—	—	—
5. Bijapur	199.00	128.29	135.00	116.88	118.50	88.15	98.84	104.21	106.50
6. Chickmagalur	102.38	118.32	89.52	98.76	82.70	92.65	97.10	119.80	132.17
7. Chitradurga	104.85	127.12	110.98	114.41	100.81	92.96	102.38	117.25	115.50
8. Coorg	97.50	162.38	103.07	110.90	100.35	98.52	103.30	126.37	127.49
9. Dharwar	108.00	120.05	107.22	101.04	90.39	91.25	97.00	124.92	137.00
10. Gulbarga	99.00	140.12	106.50	111.00	112.00	96.00	86.00	127.00	170.00
11. Hassan	109.22	119.88	104.66	106.62	89.79	92.95	102.30	131.87	157.68
12. Kolar	116.25	142.44	89.06	121.88	107.26	93.82	108.93	136.40	152.76
13. Mandya	115.64	126.23	101.38	102.75	92.00	92.00	99.00	125.70	140.43
14. Mysore	107.55	133.31	98.51	108.80	98.02	94.00	108.00	126.60	129.63
15. U. Kannada	123.50	121.07	122.02	103.97	98.51	91.03	96.17	116.49	133.66
16. Raichur	105.82	92.43	91.95	111.65	100.00	92.80	97.38	120.88	131.00
17. Shimoga	101.00	120.62	97.98	99.61	93.16	96.79	103.10	120.31	140.11
18. D. Kannada	139.39	147.62	125.78	101.50	104.04	102.97	105.31	113.98	148.74
19. Tumkur	126.89	151.16	102.01	119.38	100.00	94.44	102.65	127.50	155.30
State Weighted Average	119.44	130.43	106.07	105.56	97.35	94.81	100.92	120.49	137.33

## COMMODITY : K. JOWAR

District	1973-74	1974-75	1975-76	1976-77	1977-78	1978-79	1979-80	1980-81	1981-82
1. Bangalore	—	—	—	—	—	—	—	—	—
2. Belgaum	133.25	166.43	134.12	117.09	104.60	84.25	100.61	174.72	134.57
3. Bellary	100.43	151.37	90.93	114.63	69.41	83.75	98.00	123.00	179.00
4. Bidar	117.87	125.96	104.50	107.38	89.59	77.55	85.00	105.70	125.63
5. Bijapur	105.60	145.61	90.00	112.29	95.13	74.76	94.71	124.17	112.64
6. Chickmagalur	115.91	156.00	104.45	124.92	82.12	84.37	88.35	115.25	112.87
7. Chitradurga	127.34	138.63	89.19	137.33	75.75	76.74	95.23	131.35	156.00
8. Coorg	—	—	—	—	—	—	—	—	—
9. Dharwar	93.50	120.05	124.84	126.28	123.66	125.63	112.00	153.59	131.00
10. Gulbarga	88.00	147.62	105.38	113.69	93.00	80.00	81.00	100.00	122.00
11. Hassan	113.54	148.50	67.75	—	78.70	66.45	81.03	118.87	135.74
12. Kolar	—	—	—	—	—	—	—	—	—
13. Mandya	103.50	—	93.00	100.38	86.00	88.00	91.00	129.98	170.21
14. Mysore	107.30	124.98	88.31	112.85	92.00	114.00	93.01	114.30	137.43
15. U. Kannada	—	—	—	—	—	—	—	—	—
16. Raichur	121.37	126.73	89.65	114.90	90.00	72.83	93.84	108.00	114.00
17. Shimoga	88.00	147.25	63.20	111.33	73.00	67.44	89.25	110.21	145.00
18. D. Kannada	—	—	—	—	—	—	—	—	—
19. Tumkur	108.40	145.85	83.25	103.17	92.00	83.78	88.00	120.40	45.98
State Weighted Average	114.55	144.91	107.67	116.13	93.12	86.76	94.72	129.03	132.26

COMMODITY : RAGI

Sl. No.	District	1973-74	1974-75	1975-76	1976-77	1977-78	1978-79	1979-80	1980-81	1981-82
1.	Bangalore	130.49	168.13	83.82	131.60	100.14	92.04	99.49	167.40	154.08
2.	Belgaum	118.50	156.15	114.93	—	—	—	—	—	—
3.	Bellary	No informations were given								
4.	Bidar									
5.	Bijapur									
6.	Chickmagalur	116.40	142.37	75.82	126.30	87.77	84.16	85.80	129.13	119.92
7.	Chitradurga	117.37	148.58	58.39	125.70	79.96	70.04	92.81	128.36	126.88
8.	Coorg	—	—	—	—	—	—	—	—	—
9.	Dharwar	104.00	—	86.31	100.72	86.69	75.38	78.00	111.25	127.25
10.	Gulbarga	—	—	—	—	—	—	—	—	—
11.	Hassan	121.86	157.67	82.34	135.99	92.88	82.48	84.25	144.37	173.00
12.	Kolar	132.75	164.88	72.25	132.38	102.80	86.25	97.13	170.41	158.67
13.	Mandya	115.74	157.58	83.00	130.63	106.00	94.00	94.00	135.51	167.23
14.	Raichur	No informations were indicated								
15.	U. Kannada									
16.	Mysore	99.80	119.36	94.77	122.21	92.00	78.00	93.93	153.56	162.15
17.	Shimoga	114.00	161.61	83.33	118.01	93.58	77.07	83.07	132.68	137.80
18.	D. Kannada	—	—	—	—	—	—	—	—	—
19.	Tumkur	127.24	154.74	87.17	129.50	99.00	90.95	93.00	148.10	160.60
State weighted average		121.25	154.78	81.85	129.02	96.89	85.51	93.74	145.02	147.35

COMMODITY : WHEAT

Sl. No.	District	1973-74	1974-75	1975-76	1976-77	1977-78	1978-79	1979-80	1980-81	1981-82
1.	Bangalore	—	—	—	—	—	—	—	—	—
2.	Belgaum	220.43	188.45	116.53	165.51	163.10	161.80	181.80	247.50	251.17
3.	Bellary	No informations were indicated								
4.	Bidar	195.15	187.21	121.76	171.65	160.66	154.41	173.75	251.51	226.85
5.	Bijapur	—	—	127.00	148.13	152.38	141.51	161.48	189.25	201.86
6.	Chickmagalur	No informations were indicated								
7.	Chitradurga									
8.	Coorg									
9.	Dharwar	240.00	192.55	151.46	194.46	171.09	184.46	174.00	198.64	210.09
10.	Gulbarga	208.00	193.15	142.62	189.75	186.00	182.00	211.00	263.00	254.00
11.	Hassan	No informations were indicated								
12.	Kolar									
13.	Mandya									
14.	Mysore									
15.	U. Kannada	No informations were indicated								
16.	Raichur									
17.	Shimoga	No informations were indicated								
18.	D. Kannada									
19.	Tumkur									
	State weighted average	223.57	187.08	134.54	179.44	168.39	169.15	180.31	250.65	229.32

COMMODITY : MAIZE

Sl. No.	District	1973-74	1974-75	1975-76	1976-77	1977-78	1978-79	1979-80	1980-81	1981-82
1.	Bangalore	111.70	—	77.04	110.95	104.26	90.26	102.40	136.81	137.18
2.	Belgaum	111.76	154.81	81.24	119.75	100.00	84.00	96.18	110.69	162.34
3.	Bellary	79.78	121.50	85.00	85.00	95.00	80.63	91.00	109.00	126.00
4.	Bidar	—	—	—	—	—	—	—	—	—
5.	Bijapur	103.79	132.61	89.25	108.60	95.67	84.55	100.14	110.32	145.50
6.	Chickmagalur	—	—	—	—	—	—	—	—	—
7.	Chitradurga	—	—	71.70	108.13	93.25	90.59	96.80	122.77	151.00
8.	Coorg	No informations were indicated								
9.	Dharwar									
10.	Gulbarga									
11.	Hassan									
12.	Kolar	103.71	158.00	—	107.50	100.04	80.20	91.22	133.95	147.75
13.	Mandya	—	—	—	—	—	—	—	—	—
14.	Mysore	—	—	159.03	111.75	95.00	86.00	99.95	107.10	136.37
15.	U. Kannada	No informations were indicated								
16.	Raichur									
17.	Shimoga									
18.	D. Kannada									
19.	Tumkur	—	—	75.63	113.71	92.00	88.60	97.25	121.65	141.75
State weighted average		105.90	151.74	89.45	109.39	98.23	84.73	97.04	115.24	148.61

The Food Supply System of Bangalore

## **SUPPLY, DISTRIBUTION AND CONSUMPTION OF MILK IN BANGALORE**

**THOMAS P BENJAMIN \***

### **INTRODUCTION**

Milk and milk products form an important food item in the human diet, particularly as a source of animal protein. In India milk is the only acceptable source of animal protein to most communities.

Traditionally, milk required for the household was produced in the household or purchased from a neighbour. Milk was consumed in the form of buttermilk, in beverages, or as products like ghee, butter and sweets apart from its direct consumption.

Urbanisation and the consequent specialisation in occupations and food production, gave rise to the concentration of production units, resulting in the need for transportation and distribution of milk to consumer centres.

Milk is a highly perishable and bulky commodity. Traditionally milk was produced at the site of consumption, since the early sixties, milk production has been encouraged in the rural areas for hygienic and sanitary reasons. Modern science has developed technology for transport and processing of milk. The growth of the metropolis thus had a direct bearing on the production, processing and distribution technology adopted and used for dairying in the urban eco-system.

The importance of milk in the human diet and its product characteristics calls for complex, sophisticated technology and infrastructure to meet the requirements of a growing metropolis. A study of the supply, distribution and consumption of milk in Bangalore City is important for any future considerations in planning for the growth and development of the city as an urban eco-system. In this context, this paper studies the status of the milk system in Bangalore City.

The demand for milk in a city is influenced by population, consumer income, availability and supply of milk, knowledge of nutritional merits of milk, consumer preference for milk, price of milk and the distribution network for milk.

### **Availability**

The supplies of milk is influenced by the production, relative price offered for milk, transport facilities available and the demand for milk. In India, the major constraint appears to be in the production and supplies of milk. Table 1 gives an indication of the All India per capita availability of milk per day. It could be noted that the per capita availability of milk was less than 150 gms per head per day from 1940. The situation deteriorated till the seventies after which the milk supplies appear to have picked up.

---

\* *Rhusa, Vellore, Tamilnadu.*

### **Nutritional Requirements**

Milk as a food component is a superior item in terms of biological value, next only to eggs, as a source of protein and amino acids, essential for growth and maintenance of body tissues.

The minimum requirement of milk and milk products for different age groups as recommended by the nutritional advisory committee of the Indian Council of Medical Research is depicted in Table 2. The nutritional advisory committee recommended a dietary allowance of 280 gms of milk per day per capita on an average as minimum requirement for the population as a whole.

On the basis of minimum requirements, the production of milk falls short of the supply requirements in spite of India having largest cattle population in the world. In Karnataka, the percapita availability of milk was only about 111 gms per day in 1980<sup>1</sup>, even lower than the national average of 120 gms for the same year (see Table 1).

### **Requirements for Bangalore**

The supply of milk, therefore, is in short supply for the existing population. Even the best estimates of demand would not give a correct picture of the actual demand for milk, as the supply itself limits the demand for milk. Under these circumstances, the best that can be done is to estimate the effective demand for milk. Effective demand may be defined as the quantity of milk required for the population based on the recommended nutritional levels. (Production of milk utilises land and grain essential for human use. Demand greater than the nutritional requirement may be a drain on the economy and resources. Demand lower than the nutritional requirement is assumed to be not desirable). The effective demand for Bangalore may thus be estimated with the population figures available and the standard requirement of 280 gms of milk.

The effective demand for milk in 1971 was about 4.75 lakh litres, while in 1981 it was 8.50 lakh litres per day (Table-3). The estimate for the year 2001 is roughly double the present requirement of milk.

The effective demand for milk is only an indication of the magnitude of the problem faced by the milk industry in the city. The present status of the industry may be viewed with the effective demand as a bench mark to assess the potentials and prospects for the city of Bangalore.

The unorganised sector, still is the largest sector supplying milk in India. Nearly 95% of the milk consumed is supplied through the unorganised sector. The milk producer in the unorganised sector may be rural or urban producer. The milk is supplied directly to the consumer or sold to 'dudhia' who passes it to the middleman. The middleman transports it by bicycle, truck or rail and supplies to the consumer or processes it into milk products for sale to the consumers.

The organised sector is divided into the private, the cooperative and the departmental sectors. Even in the cities the market share of the organised sector is estimated to be about 30-50 percent. The Government of India has recommended that the cooperative sectors alone should have a share of about 50 percent in the country.

The private sector producer directly processes the milk and sells to the consumer through the distribution channel. The departmental sector processes the milk through the departmental collection centre, chilling centre (if required), dairy and finally sells to the consumers through the department dairy booth. The department may obtain milk from large private dairies who do not have their own market channel.

The cooperative sector obtains milk through the primary village cooperatives pooling milk at the union which processes the milk and sells to the consumer through the cooperative distribution channel.

### **Source of milk to Bangalore**

The milk supplies to Bangalore comes mostly from the Bangalore milk-shed area and the city. Before the third plan milk production was encouraged in the city. The dairy farmers in Bangalore, with the active help of National Dairy Research Institute, Bangalore developed large herds of crossbred cattle. From the sixties, however, the emphasis was to develop milk production in the rural areas adjoining Bangalore. (This is another example of the urban - rural link).

The Bangalore milk shed area comprises of a radius of about 64 kms from Bangalore which includes the entire Bangalore district and parts of Mandya and Kolar districts. The supplies to Bangalore would thus depend on the milk produced in the city and the surrounding milk-shed area. In 1972, it was estimated that nearly 5% of the milk production was in the city itself while the remaining 95% nearly 300 thousand litres, was produced in the milkshed area (Table-4).

### **Milk Supplies**

The procurement of milk into the city for consumption was estimated at about 275 thousand litres per day in 1972. Table 5 has details of the supplies to Bangalore from various sources. Bangalore dairy procures only about 15% of the total milk, consumed in Bangalore while the private channels provided the remaining milk 25% of the milk being procured from outside the milk-shed area.

In 1982, Bangalore got nearly 6.2 lakh litres per day of which, the Karnataka Dairy Development Corporation supplied 2.1 lakh litres per day. The Bangalore Dairy was established in 1965 to procure milk from the rural areas through primary cooperative societies. Chilling centres were erected at Anekal, Byrapatna and Doddaballapur and later farm coolers at mandya and Kolar to facilitate the collection of milk. In 1974 the Bangalore Dairy became a part of the Karnataka Dairy Development Corporation. As a part of KDDC, milk is procured by Bangalore Dairy from Hassan, Mysore and Tumkur districts.

The Bangalore Dairy procures milk at Rs. 2.10 paise for 3.5 percent fat and 8.5 percent SNF from the Society in cans and transports it to the dairy or the intermediate chilling centres. From the chilling centres, milk is transported in cans. The transportation costs, it is estimated to be about twenty paise per litre.

The departmental sectors produce and supply milk primarily for their own requirements. National Dairy Research Institute, Military Dairy and Agricultural University are examples.

The private sectors supply milk in can to the supply centres in the city. The unorganised private sector consists of farmers who supply milk directly to the consumers.

### **Distribution of milk in Bangalore**

Distribution of milk consists of processing, packaging and delivery of milk to the consumer. Milk once produced or pooled by the supplier is either procured or packed before delivery or is sold directly to the consumer in the loose form. The Karnataka Dairy Development Corporation and a few private dairies process the milk and mostly pack before delivery. The suppliers in the unorganised sector mostly sell milk in the loose form to the consumer.

Processing of milk consist of classification, separation, standardisation and Pasteurisation. Pasteurisation is not a necessary process in India, as most housewives boil the milk, sometimes even if pasteurised, before use. The KDDC and a few organised dairies pasteurise the milk before sale.

Packaging of milk may be done in cans or containers. Milk in cans is sold in the loose form. Most unorganised dairies supply milk in cans. The quantity of milk can be supplied with flexibility particularly when the consumer wants, in quantities less than half litre. However, in this method the quality of milk cannot be assured.

The containers used for packing may be broadly classified into disposable and reusable containers. The natural container, the udder, is the safest and most flexible container. However the method, is not popular on a commercial basis, In Bangalore, this method is still in use, though the practice is fast dwindling.

In Bangalore, the plastic sachet used by the KDDC and a few private dairies are the disposable containers. In Table 6 it may be noted that 28 percent of the households obtain milk in plastic containers. The disposable containers are more convenient to the supplier and are less likely to be adulterated. The plastic sachets are packed in one litre or half litre quantities.

The reusable containers used in Bangalore are glass bottles, used mostly by the KDDC and most private dairies. Half litre bottles are used popularly. The bottles are bulky to transport. However, the bottle is popular as a container of milk 27 percent of the households get their milk in bottles.

The bulk vending machine introduced in Bangalore has certain advantages in transportation and delivery. Milk is kept in a milk container. The consumer collects the milk from the booth by inserting a coin to obtain a measured quantity of milk. The machines were too few to assess the consumer reaction. However, nearly 15 percent of the households had accepted the concept, according to the IMM survey.

From the table 6, it may be noted that nearly 45% of the households still obtain their milk in the loose form. However, if given a choice, 21% of the households would prefer milk in bottles, 32% in plastic bags and 15% in vending machines. Only 32 percent of the households would continue to purchase milk in the loose form.

The delivery of milk to the consumer is the last stage in the channel of milk reaching the consumer. In case of the unorganised sector, as discussed earlier milk is carried directly to the consumer in cans by vendor boys or producers. In some cases the can is taken to the consumers house by the producer. The private sector supplies milk to the agents who distribute the milk to the consumer. The Bangalore dairy supplies milk to the accredited agents who deliver the milk at the doorstep of the consumer through vendor boys. The KDDC spends about 7 paise per litre for transportation and distribution.

Table 7 presents the delivery pattern in the city. It may be noted from the table that 45 percent of the households collect their milk from the agents or private suppliers. Door delivery by vendor boys are about equal between the KDDC and the private sectors. If given a choice, about 45% of the consumers wanted their milk to be supplied by vendor boys of the KDDC supply system, the shift being mostly from the self-collection category of consumers.

### **Consumption of milk in Bangalore**

The consumption pattern of milk in Bangalore was studied by the Institute of Marketing & Management, Bangalore in 1982. Their findings provide a useful cross-section of the milk consumption pattern of Bangalore.

### **Consumption of milk**

The per capita consumption of milk estimated in 1982 by the IMM study was about 272ml<sup>2</sup>, while the estimate in 1972 was about 170ml<sup>3</sup>, an increase of about 33 percent during the decade. This may be compared to the effective demand, based on minimum nutritional requirements, that we calculated for 1981 : 8.5 lakh litres.

### **Type of milk**

Milk is produced chiefly by cows and buffaloes in India. In India, nearly 60% of the milk produced is from buffaloes while the remaining 40 percent is from cows. In South India the consumers, however prefer cow's milk. In Bangalore

city, the KDDC supplied processed milk which is a combination of cow and buffalo milk. The vendors in the unorganised sector provide cow or buffalo milk, depending on the consumer preference.

From Table 8 it may be seen that about 59 percent of the households get pure cows milk while only about 4 percent get buffaloes milk. Nearly 55 percent of the household get processed or combined milk. The consumer preference in Bangalore, it may be noted, is for cows milk with the combined milk accepted in preference to the buffalo milk.

### **Source of Milk**

The milk required by the consumer may be obtained from 4 main sources, the domestic, the vendor, the private dairy and the KDDC. The domestic source consists of milk production in the city and supply directly to the consumer. The vendors insist on suppliers who collect milk from producers and supply in cans to the consumers. The private and the KDDC are organised dairies processing and supplying milk to consumers through organised channels. From Table 9, it may be seen that the KDDC supplies nearly 45 percent of the milk to 53 percent of the households, forming the single major sector for the supply of milk in Bangalore.

Only about 4 percent of the milk is procured directly from the producers in the city. However, it may be pertinent to know that nearly 18 percent of the households would prefer to go in for production of milk or procure from the domestic sources. The trend may suggest that the quality of milk supplied by other sectors may be poor. The private sector and the vendors have about the same market share in the city.

### **Price of milk**

The price of milk has a direct influence on the consumption of milk. The KDDC, provides the cheapest milk. This could explain the extent of its market share. The private dairy on the other hand has the highest rates per litres of milk (Table 10).

### **Mode of use of Milk**

Milk is used in different forms for consumption. Milk is used in the form of liquid milk, in beverages and as curds or buttermilk, milk may be converted into sweets, ghee or butter etc., for consumption. Table 11 provides a picture of the use of milk in Bangalore city.

From Table 11 it may be noted that nearly 41% of the milk is used in beverages such as tea, coffee and to a lesser extent in malted milk. Only 30 percent of the milk is used directly as milk.

### **Household consumer profile**

The consumer profile of the average householder in Bangalore is discussed in this section. The pattern of the family and their propensity to consume milk is discussed to provide an understanding of the average consumer in Bangalore.

The average family size of the households surveyed in Bangalore was about six, with about 74 percent of the family members being above 16 years of age, the remaining being less than 15 years of age. 75 percent of the households surveyed are literate. Among the households surveyed, 21 percent of the members were wage earners, and 11 percent self employed and the remaining 68 percent were dependents. The dependency ratio was 2.13 persons per earning member. (This sample is a poor representation of Bangalore's population – the Rao-Tewari sample is much more accurate. These results, therefore, need cautious interpretation-ed.)

The households were categorised, based on religion into Hindu (81%), Muslims (4%), Christians (7%), and the remaining (8%) into other category comprising of Jains, Buddhists, Sikhs and Jews. Nearly 49% of the households were pure vegetarians while the remaining 51% of the households consumed meat at home.

The average annual income of the households studied in Bangalore was Rs. 18,447. 62% of the income was through wages, 3% from agriculture, 27% from business, 3 % from subsidiary occupation, 4% from assets and 1 percent from other sources of income. The households spent nearly 60 percent of their total expenditure on food and only 40 percent on non-food items ; nearly 14 percent of the expenditure was on milk and milk products.

The household expenditure on milk was categorised into three main classes by the IMM.

Class I	...	Low expenditure	....	monthly expenditure of less than Rs 100 on milk.
Class II	....	Medium -do-	....	monthly expenditure of less than Rs 200 but more than Rs 100 on milk.
Class III	....	High -do-	....	monthly expenditure of more than Rs. 200 on milk.

The consumer profile of the above categories are presented in Table 12. From Table 12 it may be seen that there is a distinct association between income and consumption of milk. It was concluded from the IMM study, that though the income was doubled in the high expenditure group, the per capita consumption of milk was trebled when compared to the low expenditure group. Milk consumption was also influenced by the family size dependency ratio and the diet (food habits) of the household as evident from the table above. (However, given that non-consumer of milk, whose need is an input into calculating the effective demand for milk, are inadequately represented in this survey, these conclusions need to be used with great care, Ed.)

#### **The Institutional Sector.**

An important market for the milk system in Bangalore are institutions such as hospitals, hotels, hostels, canteens, industrial houses, offices and so on which overlap with the consumer (house hold) sector depending on the quantity of milk required. Discussions about the institutional demand was not possible due to the lack

of authentic study in this sector. However, the demand estimates may remain the same for the population considering the effective demand of milk. The mode of distribution, packaging and pricing may be influenced by the quantity of supply and institution. The planners of the urban ecosystem will have to keep the institutional sector also in mind while considering the overall plan for the urban agglomeration of Bangalore.

### **Problems facing the milk system**

The problems faced by the administrators and the supplier of milk may be broadly classified into three.

1. Seasonality of production and supply
2. Supply short of effective demand
3. Distribution of milk

### **Seasonality of production**

The production of milk is influenced by the season of the year. The period, January to April is the normal production period, producing about 35 percent of the production during the year. The period May to August is the lean season with only about 20 percent of the years milk being produced during this season. The months September to December is the flush season during which period, about 45 percent of the years milk is produced. The seasonal variation in supply and the near constant demand for milk requires that the suppliers have to conserve milk during the flush season for the lean season. In Bangalore, the KDDC gets its normal requirement of milk only during the flush season (about 2,10,000 litres per day). During the other seasons, milk is reconstituted for supply to the consumers with milk powder and butter oil.

### **Supply short of demand**

A review of the discussion earlier in the paper will indicate the short fall of milk supply to Bangalore with respect to the nutritional requirements. The figures displayed in Table 13 are self-explanatory.

From the figures it may be seen that milk is in short supply, and consumption estimates are based on the supply estimates. In 1982, the consumption estimate is higher than the supply estimates. However the fact remains, that the supply limits demand. The production of milk, therefore, is too low even to provide the nutritional level of milk to the people of Bangalore. (It is also too expensive for a large segment of the population). The milk suppliers of Bangalore therefore, have to endeavour to increase production and increase supplies to Bangalore (Longer term solutions will require an increase in the incomes of the poorer sections. To this extent this is one aspect of overall development strategy-ed).

### **Distribution of milk**

The physical distribution of milk to the consumers is arranged by the respective consumers. The issue of greater importance is the correlation between milk

consumption and the family income. It was seen earlier that the relationship is high. A pilot study undertaken in Bangalore among the weaker sections in Bangalore revealed that milk was of low priority in such families<sup>4</sup>. Earlier the relationship between income and milk consumption was illustrated. The problem for the suppliers would be to make milk economically available to the lower income category.

The pattern of consumption of milk in Bangalore, it was noted, was mostly in beverages such as tea or coffee (42 percent). It may be pertinent to note that the NDDDB had introduced "tea enricher" a product to cater to the low income category were mainly consumers of milk in beverages<sup>5</sup>. The suppliers may introduce similar products to distribute milk to all sections of the population.

## **SUMMARY & CONCLUSION**

This paper is an attempt to review the status of the milk distribution system in Bangalore city to assist planners of the milk distribution system to keep pace with the growth and development of the city.

The effective demand for milk (demand based on the average percapita nutritional requirement of milk) for Bangalore city was estimated at about 8.50 lakh litres per day in 1981, 14.50 lakh litres in 1991 and 16.25 lakh litres per day in 2000 A.D. The present availability of milk was shown to be far below the requirements of Bangalore city.

Most of the milk procured for supply to Bangalore city comes from the milk shed area around Bangalore. In 1975, the estimate was 95 percent from the milk shed area and the remaining from the city itself. The consumers of milk in Bangalore got their milk mostly from private and cooperative sectors. After the formation of the Karnataka Dairy Development Corporation, milk from Hassan, Mysore, Tumkur, Erode and Chittoor have been procured through the milk grid.

The distribution of milk : processing, packaging and delivery of milk to the consumer today is largely undertaken by the dairies : few in the private sector and the dairy development corporation have processing facilities. Packaged forms include the loose form, disposable and reusable containers and the bulk vending machine. The trend appears to be towards a greater demand for the disposable and bulk vending methods of packaging milk. The delivery of milk in the household sector is by self collection, vendor boys of both KDDC and private dairies.

The consumer in Bangalore city mostly buys cows milk or combined and reconstituted milk. Only 5% of the consumers surveyed seemed to prefer buffalo milk. The milk procured from the Dairy Development Corporation is cheaper than the other source of milk.

The consumer profile of the Bangalore city consumer indicated quite clearly the potential for the increased consumption of milk with increase in the real or dis-

posable income of the consumer. Double the present income in the low income groups can treble the demand for milk.

The emerging demand for the average consumer in the city is for clean (not necessarily pasteurised) cows milk in convenient containers supplied at the door step for a reasonable price that is mostly used in beverages.

Important considerations for the planners of the urban eco system, considering the milk distribution system are :

- (1) The present demand for milk is limited by the supply of milk and the purchasing power of a large section of the city. To make available the milk to all the dwellers in the city, an important consideration should be in increasing the real income of the population with low income with alternate and upgraded employment opportunities.
- (2) Considering the seasonality of milk production and constant demand, the supply system and processing sector has to be developed for optimum all season supply of milk. This would require a competitive pricing system to stimulate milk production.
- (3) The milk distribution system would have to develop a suitable product to cater to the average and most frequent user of the milk system, developing products for the low income groups, use in the beverages and direct consumption of milk.

### **References**

1. Census of India : 1981, Series 9, Karnataka, Provisional Population Totals.
2. The Economic Times Special Survey, **The Economic Times**, 13 May 1981.
3. Jayachandran, C, "Marketing Milk for Economically Backward Sections—Challenge of the Eighties". Seminar on Improved Marketing of Milk Products and Reducing Operational Costs in City Dairies, July 24-25, 1982, Bangalore.
4. Institute of Marketing and Management, "Milk Marketing Strategy for Household Consumers—A Study of KDDC Project Area". I.M.M. Bangalore Chapter.
5. Narayanan, R., Consultant (Marketing), KDDC, Interview 13 Dec. 82.
6. Nyholm, K. Muller, H. S., Westergaad, K., "Socio—Economic Aspects of Dairy Development—Report from the Bangalore Milk—Shed area, Economic and Political Weekly (Dec. 1974)
7. Report of the National Commission on Agriculture, Part II, Policy and Strategy.

TABLE-1

**Availability of Milk**

Year	Percapita availability gms/day
1941	147
1951	150
1961	126
1971	107
1980	120

**Source :** The Economic Times Special Survey, *The Economic Times*, Bombay Table 1, p. IV

TABLE-2

**Recommended Nutritional Requirements of Milk**

Age Group	Milk required per capita in a balanced diet (gms per day)	
	Vegetarian	Non-Vegetarian
Infants	300	200
School children	250	200
Adolescents	250	150
Expectant & Nursing mothers	325	225
Adults	200	100

**Source :** Report of the National Commission of Agriculture, Part II, Policy & Strategy, p. 188-189.

TABLE-3

**Effective Demand for Milk in Bangalore**

Year	Population (lakhs)	Demand per day (lakh litres)
1971	17	4.75
1981	30	8.50
1991	42*	14.50
2001	58*	16.25

\*Assuming a 40% increase in population. The increase in population was a phenomenal 75% during 1971 to 1981. The district average was about 35% in 1961-1971 and 45% in 1971-81. An average of 40% was assumed for future decades. (Census of India, 1981, Series 9, Karnataka, Provisional population totals, ed. B. K. Das).

TABLE-4

**Estimate of Total Dairy Production in Bangalore Area, 1978**

Area	Daily milk production (litres)
In Bangalore City	87,200
In Bangalore milk-shed	303,000
Total area	390,200

**Source:** K. Nyholm, H. S. Mulleer, K. Westergad, "Socio-Economic Aspects of Dairy Development-Report from the Bangalore Milk shed Area, **Economic & Political Weekly** (Dec. 1974), A-129

**TABLE-5**  
**Milk Procurement in Bangalore**

1971 (a)		1982 (b)	
Source	Litres	Source	Litres
City & Private channel	87,000	KDDC	2,10,000
Milk-shed through Bangalore Dairy	38,000	Private organised	60,000
Private Channel	90,000	Unorganised and department	3,50,000
Outside Milk shed through private channel	60,000		
<b>Total</b>	<b>2,75,000</b>		<b>6,20,000</b>

**Source :** (a) Nyholm, et.al., loc. cited  
(b) Karnataka Dairy Development Corporation Bangalore

**TABLE-6**  
**Packaging System in Bangalore**

Package	Present	Preferred
Loose	45	32
Bottles	27	21
Plastic bags	28	32
Vending machines	—	15

**Source :** Institute of Marketing & Management Milk Marketing Strategy for Household Consumer-A study of KDDC Project Area, p. 76 & 77

TABLE-7  
Delivery Pattern - Present & Preferred

Type of Delivery	Present	Preferred
Self	45	32
KDDC Vendor	29	45
Private Dairy Vendor	23	23
Other	3	

Source : Institute of Marketing & Management "Milk Marketing Strategy for Household Consumer-A study of KDDC Project Area", p. 78 & 81.

TABLE-8  
Type of Milk Consumed

Type of milk	Quantity %	Households* %	Preference %
Cow	50.25	59	59
Buffalo	2.85	4	5
Combined	46.87	55	37

\*The percentage is greater than 100 in total as there will be houses procuring more than one type of milk.

Source : I.M.M. p. 50, 52, 71

TABLE-9  
Source of Milk Supply in Bangalore

Source	Quantity %	Households* %	Preference* %
Domestic	4.34	3	18
KDDC	45.53	53	45
Private	21.55	27	18
Vendor	27.80	34	19

\*The total is greater than 100 as some households procure milk from more than one source of supply.

Source : I.M.M. p. 53 and 74

TABLE-10  
Price of Milk in Bangalore

Source	Cow	Buffalo	Combined
KDDC			2.80
Private Dairy	2.95	3.26	3.00
Vendor	2.86	3.23	2.90

Source : I.M.M: p. 62

TABLE-11  
Percentage Distribution of Liquid Milk by Different Uses

Use	%
Liquid milk	30
Beverages	41
Curd	26
Others	3

Source : I.M.M., p. 68

TABLE-12  
Consumer Profile of Houesholds Under Three Expenditure Category  
LOW, MEDIUM and HIGH

Variable	Expenditure Category		
	Low	Medium	High
Family Size	5.00	6.00	6.00
Dependency Ratio	2.38	2.22	2.0
Vegetarians %	41.00	59	70
Non-Vegetarians %	59.00	41	30
Income (Rs.)	13,217	20,166	27,213
Per capita Consumption (ml)	140	255	449

Source : I.M.M. p.29.50

TABLE-13

**Per capita availability of Milk**

<b>Per capita availability</b>	<b>1972</b>	<b>1982</b>
<b>Supply (ml)</b>	<b>170</b>	<b>200</b>
<b>Consumption (ml)</b>	<b>170</b>	<b>227</b>
<b>Requirement (ml)</b>	<b>280</b>	<b>280</b>

# **ELEMENTARY EDUCATION IN BANGALORE CITY**

**S. Nayana Tara \***

## **1. General :**

**1.1 Bangalore happens to be one of the largest metropolitan cities with a population of 29,13,537. The population of this urban agglomeration in the year 1971 was 16,53,779. There has been a phenomenal increase of 76.17% over the previous decade of 1971-81. This is due to the inclusion of several new out-growths to the agglomeration forming a contiguous spread of Bangalore in all directions. The increase in population can be attributed to the industrial boom. Fifty-nine percent of the population of Bangalore District is resident within the limits of the Bangalore urban agglomeration.**

**1.2 Bangalore revenue district comprises of three educational districts : 1. Bangalore North ; 2. Bangalore South and 3. Bangalore Rural. In this educational study of Bangalore City, Bangalore North and Bangalore South districts only are considered. This study highlights the number of schools, enrollment, number of teachers, teacher-pupil ratio, curricular aspects and other infrastructural facilities of the school system.**

**1.3 Bangalore is the capital of Karnataka. Out of 23,359 schools in Karnataka, 768 are in Bangalore City. Out of the total enrollment of 51,60,815 children in Karnataka, 4,87,949 are enrolled in Bangalore. There are 35,098 teachers in Karnataka of which 2,640 are working in Bangalore City. [Source: District At A Glance 1982-83 by Deputy Director of Public Instruction Bangalore City (South and North)].**

**1.4 In Bangalore City we find three patterns of schooling : a) the State pattern ; b) the Central Board of Secondary Education and c) the Indian Council of Secondary Education pattern. There are seven Kendriya Vidyalayas in Bangalore and a few more private institutions following this pattern have also cropped up recently. There are about 12 institutions following the ICSE pattern.**

**1.5 The schools in Bangalore City are managed by various bodies - Government, Corporation, Private Aided and Private Unaided.**

## **2. Enrollment :**

**2.1 It is interesting to study the trend in enrollment pattern during the past 3 decades. This has to be studied in relation to the growth in schools. Table 1 indicates the growth rate in the number of schools and enrollment, taking 1960-61 as the basal year.**

---

\* *Institute for Social and Economic Change, Bangalore*

2.2 Another aspect is the pattern of enrollment of children under Compulsory Primary Education in 1982-83 (Bangalore City). The Table 2 indicates the number of children enumerated and enrolled, sex-wise and also the percentage yet to be enrolled.

It could be seen from table 2 that 5% of the eligible population remain out of school. This indicates the need for an enrollment drive by the Education Department to achieve 100% enrollment. The difference between enrollment of boys and girls is only 2% which is marginal.

2.3 It is now envisaged to present data pertaining to number of schools, number of teachers and enrollment-media-wise. Distribution of pupils by grade and sex is shown in Figure 1.

2.3.1 Bangalore City exhibits the characteristics of an all-India pattern in as much as there are schools with nine media including English and Hindi (Table-3). It may be specially noted that there are as many as 12 Hindi medium schools which shows that the Hindi speaking population is spread over in different parts of Bangalore City.

2.3.2 It may be observed that the teacher-pupil ratio is the highest (1:105) in English medium schools as against 1:27 in Hindi medium schools. It may also be noted that in Kannada medium schools the ratio is 1:44. This too, as an average, indicates that it is fairly higher and needs to be lowered. It is not understood how the English medium schools manage with the staggering average of 1:105. This point needs a closer study.

2.4 Enrollment Grade-wise and Media-wise: A rough drop out rate can be seen from enrollments in Standard I, V and VII. 40% dropout before getting into Grade V and 54% at the end of Standard VII in the case of Kannada Medium Schools. In English Medium Schools 40% dropout by the time they enter grade V and 54% dropout by grade VII.

3. Data regarding number of teachers trained and untrained, sex-wise, in LPs and HPs is shown in Fig 2. There are still 13.25 untrained teachers in LPs and 7.03% in HPs. Two reasons for this may be: 1. Some teachers were appointed prior to the rule that only trained teachers should be absorbed; and 2. Teachers belonging to SC/ST being exempted from training.

This indicates a need for provision for training all untrained teachers, deputation of teachers for training with full pay and training them in in-service courses.

#### 4. School Buildings :

The position regarding school buildings is that only 46.8% of schools have their own buildings; 38.94% conduct schools in rented buildings and 14.25% in rent free buildings. Statistics pertaining to number of classrooms show that only 5,294 classrooms exist as against a need of 7,603 required in order to have 50 pupils per classroom. Hence 2,309 more classrooms have to be constructed. The above data

indicates accommodation is grossly inadequate and there is an imminent need for more school buildings to be constructed.

#### **5. Shift System :**

For want of accommodation, a fairly large number of schools (exact number is not available) have resorted to the Shift System. Such a system has the following repercussions: 1. Less number of working hours; 2. Crowded classrooms; 3. No attention to slow-learners due to lack of accommodation; 4. Organization and admission also are confused especially where one and the same Head operates for both shifts-which is seen in some schools; and 5. Subjects like SVPW, PE, Art etc., are neglected.

#### **6. Single-teacher Schools :**

In Bangalore City there are 131 single-teacher schools. This is one of the reasons for children dropping out of schools. In a big city like Bangalore, existence of such schools are not justified. Children can easily commute to a neighbourhood school and this aspect of single-teacher schools requires a deeper study.

#### **7. Administration :**

Bangalore City schools are administered by 2 Deputy Directors of public Instruction, both under the control of the Joint Director, Bangalore Division. Bangalore City is divided into 6 ranges with one A.E.O in charge of each range. Each A.E.O. is assisted by 3 Inspector of Schools. Hence there are 6 AEOs 18 IOS in Bangalore City, with other supporting staff. Each IOS has to supervise an average of 62 schools per year. Realistically speaking, to do full justice to their work, it is possible only to inspect 30 schools per year which they must inspect at least twice in a year. This is a felt need to strengthen the Inspectorate to ensure qualitative improvement.

#### **8. Education in Slums**

Slums are the byproducts of the process of urbanisation. During 1971 there were 159 slums in Bangalore City. Slum schools have peculiar problems of their own. The study by Seetharamu (1983) of 20 slums in Bangalore City, pertaining to educational factors have shown some interesting findings. The study has shown that 24.4% of children leave school before even completing the I standard. It is recommended that greatest care and attention has to be given to children when they are just enrolled and the learning programme should be made simple, relevant, meaningful and effective. To this end UNICEF has undertaken Project II in 10 slum schools in Bangalore City. It has been in operation for the last 2 years and its progress has to be watched from the stand-point of its efficacy.

In the slum areas it is of great importance to find out the major language spoken, in order to start schools with appropriate media of instruction. Otherwise this becomes a cause for children dropping out of schools. Seetharamu's study has also shown that when regular and dropout children are compared in the back-

grounds of mother tongue and media of instruction, it was observed that facilities for Tamil and Telugu mother tongue children appear to be quite inadequate. Mid-day meal program must be intensified in slum schools for reducing drop-out phenomenon.

Coming to the provisions made by the State Government for Compulsory Primary Education, during 1961 The Compulsory Primary Education Act was brought into force. The major aim was to bring all children in the age group of 6–10 years into the fold of universal primary education. It has resulted quantitative expansion in terms of number of schools, teachers and enrollment. The context in which this remark is made is as follows : The NCERT has drawn up a set of National Goals for education as well as objectives for primary education. 1. It is found that the State syllabus is lower than that of Central syllabus. 2. Even in the existing science syllabus of our State, the science and maths content is high and teachers don't have adequate knowledge of the subject matter. 3. The amount of science content necessitates laboratory facilities but most schools are ill-equipped in this regard. 4. Most teachers teach science subject like any other language subject without any practicals. Even in good schools, questions and answers are dictated instead of giving them first hand experience like field trips to learn by one self. This aspect requires deeper study. 5. Lack of proper accomodation is yet another draw back. All these aforementioned factors affect qualitative improvement in schools. Some studies conducted in Bangalore City highlight this aspect. Study done by Swamy, S (1983) shows the need for creating a conducive organizational climate in schools for increasing the competency of teachers. George, R (1981) in his study has shown a need for finding out the aptitude of teachers for teaching before they are recruited. The highlights of Murthy, G. N.'s (1977) study are that : 1. Objective outlook has been given the most predominant place in both Nationalised Science Text Book and Standard Science text book of Meghalaya. 2. A Little emphasis is made on the other objectives like spirit of Enquiry, Keen Observation etc., and the objectives of suspended judgement and Open-mindedness have been totally ignored in both text books.

In order to intensify Compulsory Primary Education in the State, the Karnataka Government has taken up 40 taluks on an experimental basis to improve enrollment, attendance etc., by providing incentives, providing school buildings etc. This project does not cover Bangalore City. As a part of literacy drive they have also started 3,342 non-formal education centres and 800 pre-primary centres have been attached to single-teacher schools. Again, Bangalore City does not form part of the sample. To improve slum schools, UNICEF has started Project II in 10 slums of Bangalore City. As this preliminary study has shown, dropout phenomenon is quite rampant in Bangalore City schools also and hence there is a need for starting Non-formal education centres here also.

Data collected from a random sample of 50 elementary schools of Bangalore City for the current study has revealed the following information :

1. Infrastructural facilities are inadequate ;
2. Untrained teachers continue to teach in schools ;
3. Problem of children dropping out is continuing ;
4. Text books are not being supplied on time ;
5. Teacher-pupil ratio is high, and
6. Lack of proper administrative training for MM's of schools.

A more detailed survey is called for to identify other problems faced by our schools.

**Future of Elementary Education :**

This aspect has to be viewed from two angles : I. Quantitative and 2. Qualitative.

**Quantitative :** Refers to number of schools, number of teachers, enrollments, infrastructural facilities etc.

Certain minimum norms for the above factors have been prescribed. They are as follows : 1. Floor area should be 8 square feet per pupil in a classroom; 2. Seating furniture should be adequate ; 3. Teacher-pupil ratio should be 1:30; 4. An open playground of at least a half acre or a closed hall of 30'X20' should be attached to every school ; 5. With regard to supervision, each Inspector of school should inspect only 30 schools and 2 visits to these schools in a year is a must. Every teacher's work in every school must be evaluated every year ; 6. Aids related to each subject must be made available. Every teacher must have a text and a guide book. So also every student must have text book.

It is disheartening to find that the above minimum norms are lacking in most schools.

During the year 1971, the school going population was 3,66,870. By 2001 AD it is expected to be 4,51,154 at the rate of 22.18% increase per decade. Accordingly, number of teachers required to teach at the rate of 50 pupils per teacher would be 1,686. In order to attain an ideal teacher-pupil ratio of 1:30, would amount to 2809. Number of schools and other facilities will also have to increase proportionately.

**Qualitative Aspect :**

Improving the quality of education must address two fundamental questions. The first is the general problem of the curriculum. The degree to which it provides each child with a basic education, as well as its abilities to motivate young people, to prepare them for citizenship and to expose them to culture and knowledge of work.

Curriculum should be comprehensive enough to integrate an emphasis on fundamental areas with the preparation for a life of work and democratic citizenship. This means that the following areas will have to be stressed :

1. basic reading, writing, computational and life skills ;
2. an orientation towards the personal and social environment of students so as to increase student motivation ;
3. attention to the basic democratic principles that create a sense of responsibility for citizenship ;
4. cultural breadth and depth ; and
5. taking into account student needs by involving them in decision-making processes.

In a developing country like ours, we have to reckon with rapidly rising number of pupils in primary education. This coupled with the problem of number of subjects to be taught, knowledge explosion, necessitates the curricula to be constantly updated. To impact coping mechanisms to pupils to face new challenges in the coming decades will be doubly difficult. It would be interesting to forecast the evolution of media in future to mitigate the problems outlined earlier.

Contemporary culture is characterised by a massive and rapid circulation of information, thus scientific discoveries are spread simultaneously all over the world through the mass media. During the next few years at least maths must increasingly meet the requirements of economic, social and humanistic sciences, the approach is likely to be modified. Computers will have a major role to play in education given necessary financial aid. As Malitza (1982) predicts, innovations will occur in two main directions : the first, telematics which is the result of connecting huge data-processing centres to the mass media network (communication by satellite included) ; and second, private born from the association of micro computers with video tapes, eventually branch to the communications network. Laser physics will be in the future a top priority field.

Second concern pertains to Maximization of Resource Utilization, in the context of enabling education to meet its expanding responsibilities. It must also devote attention to improved teacher training at both the pre-service and in-service levels. Media like Radio and T.V. will have to be widely used for educating swelling numbers of school going population in future.

Interdisciplinarity will undoubtedly score remarkable success. Demand for flexible forms of education requires the use of a variety of methods in formal education. Non-formal education must be carefully planned to complement and supplement formal education. Distance teaching by correspondence, broadcast courses on radio and television, supported by an array of audio-visual aids would go a long way in imparting meaningful and lasting education. Curriculum has to reflect the changes in our rapidly expanding world.

It is now proposed to offer a few suggestions in the light of the preliminary study of elementary education in Bangalore City. They are as follows :

1. There is a lack of detailed information pertaining to the problems faced by

schools. Hence a survey to identify specific needs of various types of schools both in decent localities and in slums is required.

2. We find that the percentage of pupils to be enrolled for primary education is 6 and efforts must be made to bring them within the fold of our educational system to achieve the plan targets of cent percent enrollment.

3. Formal education alone cannot solve the problem stated in point (2) because of the following reasons :

- a. Child labour
- b. Bad schools don't attract children
- c. Curriculum is not relevant and interesting
- d. Very little scope for activity and play
- e. Slum dwellers neglect education of children.

Hence Non-formal education suited to both categories (a. those not attended school at all, and b. those withdrawn or dropped out of school prematurely) needs to be planned on a larger scale. The new kind of learning materials developed by CAPE Programs may also be tried out in more number of schools.

4. Inspectorate for Primary Education needs to be strengthened. There are 6 AEOs' and 18 Inspectors of School for Bangalore City schools. On an average these people have to inspect 62 schools at least twice in a year. 30 schools per person would be ideal for them to do a thorough job of inspection.

5. We find that only 46.8% of schools have an owned building. There is a pressing need for buildings to be increased to house schools.

6. Another drawback pertains to lack of vision on the part BDA with regard to town planning. Proper location for schools and playground have not been earmarked which results in schools being housed in all kinds of unsuitable buildings and hardly 10% of schools can boast of a playground. This defeats the very aim of allround development of education.

### **Conclusion :**

The renewed picture that emerges out of the study is : 1. increasing enrollment; 2. lack of building to conduct schools ; 3. continuance of untrained teachers ; 4. no special attention being paid to the problems of the shift system and 5. inadequate supervision.

In the light of these problems, strategies to be evolved to solve them have to be designed. Special projects to study each problem in depth to offer solutions is essential. An advanced plan of action has to be drawn up by experts to forecast the problems that would arise in future and prepare to tackle them as they arise, well in advance.

A relatively painless introduction of sweeping changes over the total educational

landscape can be possible if there is co-operation between educational researchers, educators and innovating bureaucratic and decision makers. Periodic tinkering with the schools for development is important.

### BIBLIOGRAPHY

#### 1. Books and Reports :

APEID, *Universalizing Education ' Strategies for the Development and Use of Instruction Materials*, UNESCO, Bangkok, 1979.

Census of India 1981, Series-1, Part II B(i), *Primary Census Abstracts General Population*.

ISEC, Bangalore; Bangalore : *Emerging Metropolis*, Bangalore, 1976.

Karnataka, (Development of Planning), *Draft Five Year Plan : 1979-83*, Bangalore, Government Press, 1978.

Kamath, Suryanatha V, (Ed.), *Karnataka State Gazetteer (Part II)*, Government of Karnataka Publication, 1983, pp. 539-545.

Mysore Planning (Department of), *Draft Fifth Five Year Plan, 1974-79*, Government Press, 1973.

NCERT, *Annual Report, 1982-83*, 1983.

NCERT, *Education and National Development-Report of the Education commission, 1964-66*, New Delhi, NCERT, 1971.

OECD, *Future Educational Policies in the Changing Social and Economic Context*, 1979.

Seetharamu, A. S ; *Education in Slums*, Ashish Publishing House, New Delhi, 1983.

World Bank ; *Major Reforms of the Swedish Education System, 1950-1975*, Staff Working Paper No. 290, Aug. 1978.

#### 2. Articles :

Bowers, C.A. : 'Cultural Literacy in Developed Countries' *Prospects*, Vol. VII, No. 3, 1977, pp. 323-337.

Duran Graciela Ruiz : 'A Conceptual Framework for the Reform of Educational Administration', *Prospects*, Vol. VII, No. 1, 1977, pp. 65-73.

Fonesca Guilherme Dultrada : 'The Secondary-School Reform in Brazil', *Prospects*, Vol. IV, No. 1, Spring 1974, p.p. 84-92.

Lyons Raymond F., : 'Some Problems in Educational Administration', *Prospects*, Vol. VII, No. 1, 1977, pp. 58-65.

Malilza, Mircea : 'Coming Changes in Science and the Curricula' *Prospects*, Vol. XII, No. 1, 1982, pp. 89-100.

**Renon Alberto Gutierrez :** 'Training Administrators and Educational Administration Requirements', **Prospects**, Vol. VII, No. 1, 1977, pp 73-82.

**Skatkin, M.N., and Kostyashkin, E.G., :** 'Prospects for the Development of the School System in USSR', **Prospects**, Vol. X, No. 3, 1980, pp. 287-293.

**Singh Raja Royand Guruge A.W.P. :** 'Administration of Education in the Asian Region', **Prospects**, Vol. VII, No. 1, 1977, pp. 118-127.

**Souchon, Michel :** 'Education and the Mass Media : Where They differ, Where they converge', **Prospects**, Vol. XII, No. I, 1982, pp. 101-111.

**3. Unpublished Reports :**

1. George Rita, Job satisfaction of teachers in Relation to their Attitude, Interest and Aptitude in Teaching, (Unpublished Dissertation), Bangalore, 1981,
2. Murthy, I, Narasimha, G., A Comparative Study of VI Standard Nationalised Science Text book of Karnataka State with a selected text book of Meghalaya State in terms of Scientific attitude (Unpublished Dissertation), Bangalore, 1977.
3. Swamy, Shivakumara, C.D., Effect of organizational Climate of Schools on the Competency of Teachers (Unpublished Dissertation), Bangalore, 1983.

**TABLE-1**  
**Trend in Enrollment Pattern**

	1960-61	1970-71	1980-81
No. of Schools	458	667 (45.63)	1370 (199.13)
Enrollment	1,56,459	7,59,37 (51.46)	4,24,972 (171.62)

Figures in the brackets refer to percentage increase

**Source :** Statistical Brochures, 1960-61, 1970-71, 1980-81 by the Department of Public Instructions, Bangalore.

**TABLE-2**  
**Sexwise Enrollment and the Extect to be Enrolled**

	Enumerated	Enrolled	% to be enrolled
Boys	1,13,109	1,08,162	4
Girls	1,09,960	1,02,248	6
Total	2,23,069	2,10,410	5

**Table-3 : The Number of Schools, Number of Teachers and Enrollment Media-wise (1982-83)**

Medium	No. of Schools	No. of Teachers	Enrollment in Grades							Total T:P Ratio
			I	II	III	IV	V	VI	VII	
1. Kannada	895	6209	50775	44270	39306	33220	30596	26702	23884	43.91
2. Urdu	150	847	11231	9745	8985	7584	5723	5161	4784	68.47
3. Tamil	128	1021	9698	7080	6611	6475	6182	4932	4211	48.38
4. Telugu	23	94	972	1018	953	865	352	330	261	53.32
5. English	169	2292	28862	26381	34836	21728	17064	99672	13055	105.41
6. Hindi	12	81	553	624	300	355	—	—	—	27.00
7. Gujarathi	1	14	101	63	85	52	89	66	86	44.85
8. Malayalam	2	18	62	42	46	56	72	102	84	30.44
9. Sindhi	1	10	46	62	52	30	42	30	38	30.00
	1381		102300	89285	91174	70415	60120	136916	46403	5,96,612

**Source :** District at a Glance 1982-83, by the Deputy Director of Public Instructions, Bangalore City (South and North)

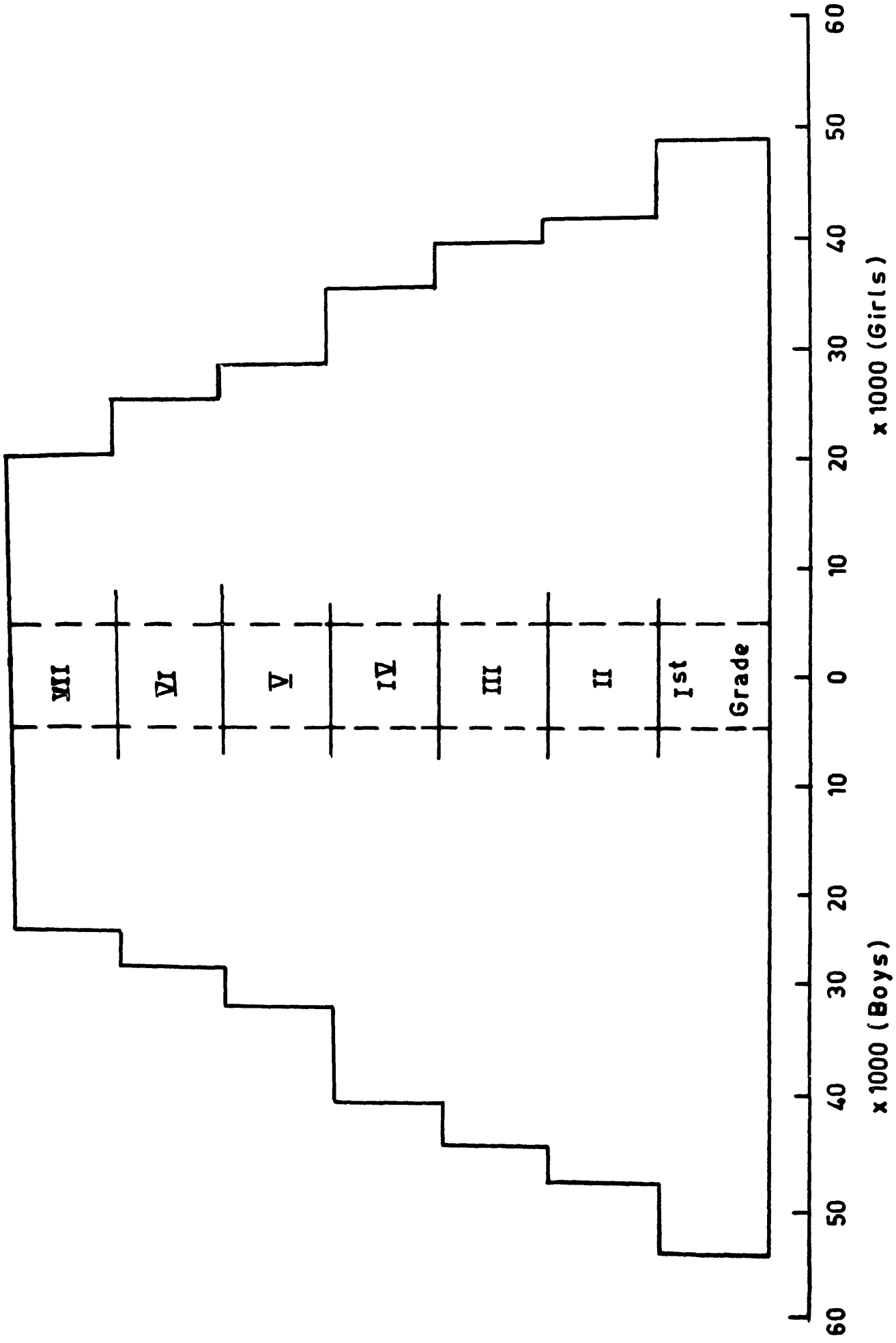
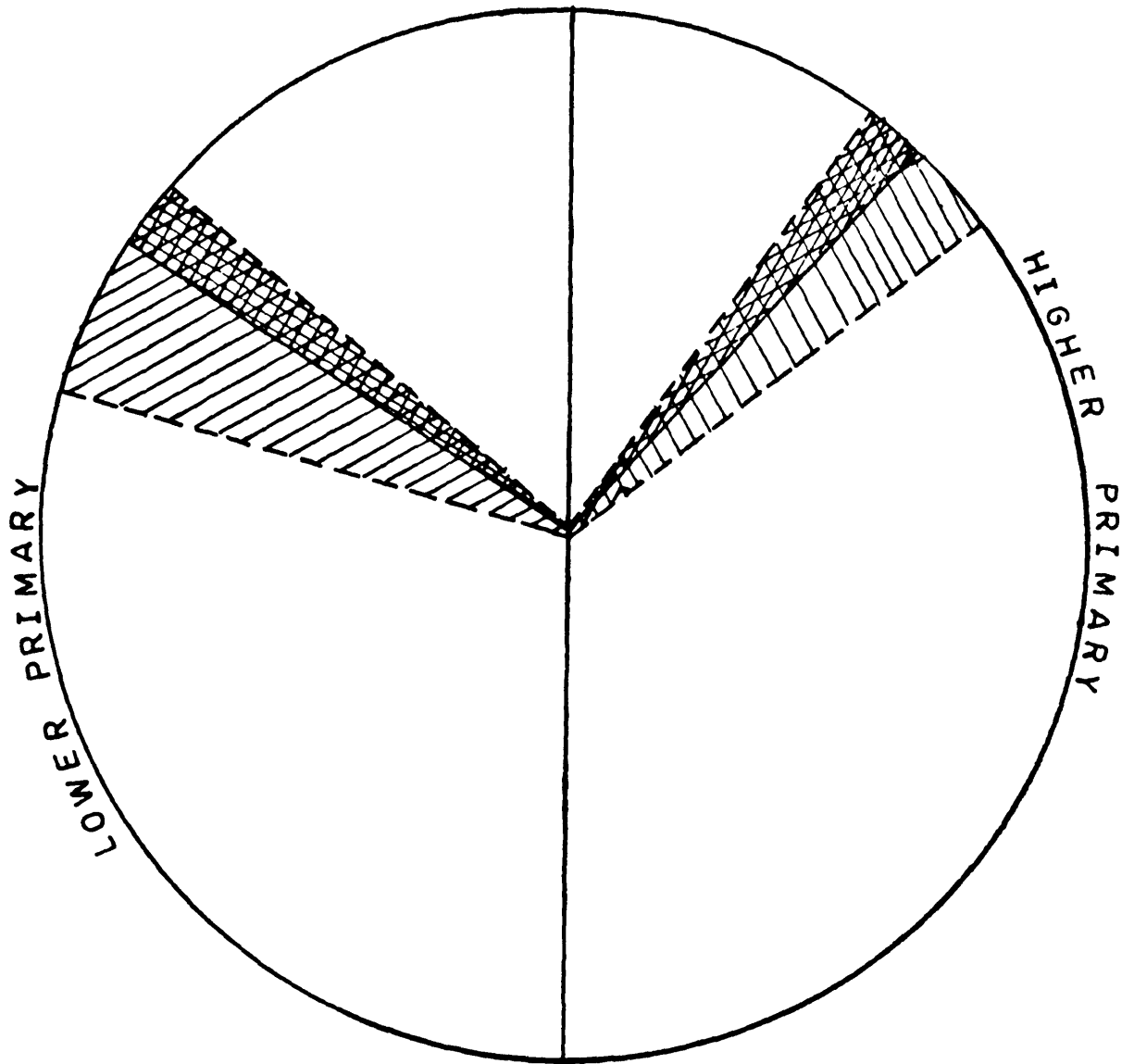

Fig. 1 - Distribution of Pupils by grade and sex



	Men	Women	Total	Men	Women	Total
No. of Teachers	791	1729	2520	1871	6175	8046
Trained	711	1475	2186	1604	5691	7295
Untrained	80	254	334	141	425	566
% Untrained	10.11	14.69	13.25	7.53	6.88	7.03

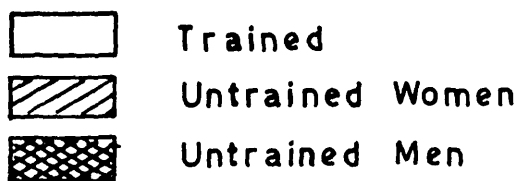

Fig.2 - Teachers in Lower and Higher Primary School



# **BANGALORE CITY'S WATER SUPPLY - A STUDY AND ANALYSIS**

**D. K. SUBRAMANIAN\***

## **1. Introduction**

Water supply has become an important lifeline in any urban environment. All our activities come to a standstill, if water is not available. The effect of growth of an urban ecosystem on water supply is direct and is felt immediately. Whereas one can live with reduced comforts as far as other basic requirements like shelter, education, transport, energy, etc. are concerned, one cannot find life easy if water is not available to meet his basic needs. The dependence of man, business, industry, gardening and other activities on municipal water is total that no alternatives are developed until a crisis develops. Another aspect of water supply to urban areas is the discarding of traditional sources (like wells, tanks, ponds, etc.) and to put our total faith on rivers.

Parameters like the growth rate of a city and planning of various subsystems like markets, services, amenities, housing colonies, etc. are closely interlinked with the development of water supply systems.

Urban water supply systems gradually developed with increasing complexity starting from traditional individual/community wells supplying water for the domestic needs. Today's systems are quite large obtaining bulk water from far off sources like rivers and transmitting it to local storage reservoirs. A complex distribution system takes over from these reservoirs supplying water to various areas comprising of different types of consumers. The various stages in urban water supply development are :

- (i) piped and protected water supply resulting in the convenience of usage (an urban housewife opens a tap in her sink in the kitchen when she wants water, whereas her counterpart in a village may have to undertake 2-3 trips per day to collect water from a source like well, handpump or pond - normally situated at a distance of 0.5 to 1.0 kilometre from her house).
- (ii) lakes or tanks to tap rain water along with a rain water drainage system,
- (iii) closed type reservoirs—both ground level and overhead ones—to store water for a shorter period—say a day or two,
- (iv) pump houses to pump water to individual households,
- (v) purification system like filter beds, chlorination etc.,
- (vi) transmission pipelines bringing water from a far off source to the city,
- (vii) waste water systems,
- (viii) recycling plants,
- (ix) groundwater tapping,
- (x) monitoring the opening and closing of valves, maintenance of water quantity and pressure at customer's end.

---

\* *Indian Institute of Science, Bangalore-560 012*

Water usage has also changed from time to time. In the earlier days, the purpose of water supply is mainly to meet domestic requirements like cooking, drinking and washing. Water was used mainly for irrigation in the neighbourhood. But presently, water is used for many purposes and activities like :—

- (i) Domestic - drinking, cooking, washing, maintenance of small gardens, etc.
- (ii) Industrial needs – processing of raw materials (including cleaning them) ; production needs and in the preparation of the final products.
- (iii) Construction needs – (of buildings, houses, roads, offices, shops, factories, etc).
- (iv) Needs of commercial establishments, hotels, gardens, transport, railways, services, etc.

Normally water is used for one activity and the resultant “waste” water is to be disposed of. Two points deserve mention here. One, that water can be used in a **cascaded** form for multiple uses. For example, water used for washing of hands, cloths, etc. can be used for gardening. The second point which is based on the first point is that every water need does not require a **high quality** water. Water requirements for various activities can be categorized into three or more groups depending on the quality of water required. For example, cooking needs a high quality soft water. Cleaning of floors, vehicles, roads, need a lower quality of water. But unfortunately, the present developments of our urban systems have discarded traditional methods so that there is no easy way of matching quality of water required with the quality of water available.

Water use can also be categorised as :

- (a) primary use – water gets mixed up in the processing activity and the waste water will be very impure (biologically and/or chemically) and needs extensive treatment before reuse.
- (b) secondary use – like cooling requirements, simple washing needs etc. Water can be reused with minimum or no treatment.
- (c) tertiary use – like steam generation in boilers in which water is pure and is reused directly.
- (d) consumption – drinking, industrial products, chemicals, food products, beverages, – water is consumed as a part of the product and hence is not available for reuse.
- (e) evaporation to atmosphere – reservoirs, curing in construction work, washing of houses, roads and vehicles, etc.
- (f) percolation to ground from leakage, waste water etc.

As can be seen from the above, a large part of the water (about 80%) is rejected as ‘waste water’. Exponential increases in the population of cities like Bangalore and

increasing needs for various purposes have resulted in a very high demand on water requirements. Because of these, there is a strong competition on the use of water between urban needs and irrigation needs. Development of irrigation from rivers like Cauvery and Arkavathy reduces water available for urban needs and vice versa. The 300 MLD (million litres/day) of water requirement of Bangalore city can irrigate 10,950 hectares of paddy cultivation or more than double that area under ragi cultivation (The total irrigated area under paddy in Bangalore district in 1979 is around 34,000 ha. and about half of this area is fed from tanks).

Similarly, cities like Bangalore have steadily stopped harvesting of rain waters. This is indicated by the fact that the number of tanks have come down drastically as shown later. Such a situation has not only reduced the available local water but also put a strain on the waste water system during heavy rains (in addition to flooding roads, streets and buildings).

Water sources, normally, are of several kinds such as community wells, wells and borewells (tapping ground water), ponds and lakes (harvesting rain water), canals, rivers and streams. A secondary source is recycled water. An indirect source is water conservation in processes and activities, minimisation of losses and leakages and evaporation losses. In the early days, because of the importance of water to our life style, cities and civilizations developed on the banks of rivers. Later on, cities started using rain waters. Even today, Bombay depends on rain for its water needs. Bangalore city initially used water from the tanks in the city and later on from the Chamarajendra reservoir. Technological advances led to tapping river waters for urban requirements. Instead of relying on them even to meet partially our requirements, we in Bangalore are looking towards our rivers to meet our needs. The water has to be pumped over large heads – over 1500'. It can be shown that cost of rain water stored on a land area costed as per BDA rates will be cheaper than cost of Cauvery water. Similarly recycled water (at around Rs. 2-3/Kilolitre) will be less costly than the Cauvery water.

We discuss here various aspects of water supply in Bangalore city – first a glimpse on the history of water supply to Bangalore city is given ; this is followed by some details of the existing water supply system ; thirdly, consumption analysis of water from the spatial and sectoral point of view is discussed ; some case studies of water use in industries, slums, households and cleaning activities are presented. Since the projections on water demand and supply show that there will be a deficit on water supply to Bangalore city, it is not worthwhile looking for new water sources based on rivers ; with further developments in irrigation, even the available quanta of water in Arkavathy and Cauvery might come down further. Hence, a discussion of other alternatives and possibilities like groundwater, rain water, recycling and water conservation follows. Table 1 gives the projections prepared by BWS & SB for supply and demand. It clearly shows a deficit reaching a staggering figure of 1375.59 million litres per day by 2001 A.D.

A glimpse of some stages in the development of Bangalore water supply system is given in the next section.

## **2. Glimpses of History of Water Supply in Bangalore**

Bangalore consisted of the city area under the control of the government of Mysore (Durbar) and the civil and military station of the Government of India. Till the year 1895, Bangalore was supplied with unfiltered water in the Karanjee system from a number of tanks such as Dharmambudhi, Sampangi, Ulsoor, Sankey etc., supplemented by local wells and stepped ponds. Because of the unsatisfactory conditions of water supply, Sri K. Seshadri Iyer, the then Dewan of Mysore observed in 1892 that we should go in for some perennial streams to supply water to Bangalore.

The first protected water supply came from Hesaraghatta lake across the river Arkavathi. The water scheme was called 'Chamarajendra water works' and was designed for a population of 2,50,000 at the rate of 55 litres per capita per day. The filtered water was supplied to the city from 7th August 1896 onwards. The Chamarajendra Reservoir is about 20 kilometres from Bangalore. Its capacity was 747.7 million cubic feet. The water was conveyed from the reservoir to Turbanahalli by a duct and then bifurcated with the city supply going to Soldevanahalli. The Jewell filters at Hebbal received the water for treatment. From here water was pumped to the Highground reservoir of the C and M station. Currently this system has been improved capable of supplying 31.5 million litres/day. It is bringing into the city about 13.5 MLD (an additional amount of 9 MLD brought by these mains are used by industries in and around Peenya). Even at that time, many agencies like Government of Mysore (PWD, Dewan etc), Government of India (Engineering Department, Secretary of State), Resident at Bangalore, municipalities of the city and C and M station, military department, were involved in the water supply system resulting in considerable delays in decision making. But, the durbar has been looking at the problem at different instants of time with a long term outlook.

From time to time as shown in the brief glimpse of water history of Bangalore, there were shortages. Improvements in pumping, installation of additional impounding reservoirs and mains were resorted to. But the major water crisis in 1925-26 due to the failure of two successive monsoons and the late arrival of the monsoon in 1926 emphasised the need for a "permanent and reliable" new source of water supply to Bangalore. A Committee under the Chairmanship of Sir M. Visvesvaraya suggested the Tippegondanahalli scheme—the construction of a dam across the Arkavathy river at T.G. Halli, about 40 kilometres from Bangalore downstream of Hesaraghatta lake. The Committee considered other alternatives like Hemavathy and Cauvery waters before arriving at this conclusion. The T.G. Halli was commissioned in 1932 and started supplying water from 1933 onwards.

From 1934 onwards, water problems—either in supply or in distribution were solved by putting up improvements in pumping and filtration as well as increasing the holding capacity of the reservoir. The supply was increased from 27 million litres/day to 72 million litres/day in 1958-59. Still, this was found inadequate as the population was found to be increasing. This gave a per capita consumption of about 90 litres/day maximum.

A Committee constituted in 1958 by the government recommended in 1961 the supply of water from Cauvery in addition to improvements to Arkavathy water supply. It suggested getting 112.5 MLD from Arkavathy and another 112.5 MLD from Cauvery 1st Stage. The Committee also felt that the 1st stage should be completed before 1968 and the second stage by 1978.

The government did not go for construction of a reservoir downstream of T.G. Halli, but increased the storage capacity of T.G Halli to 95 M.cum. By augmentation, a maximum of 140 MLD was being drawn from T.G. Halli by 1963. The government sanctioned the Cauvery scheme and water started flowing into Bangalore from 25.1.1974 onwards.

The first stage of Cauvery water supply scheme supplied 135 MLD of treated water. This water is pumped over a head of 480 metres from T.K. Halli to the South End circle terminal point at Bangalore. The second stage after completion is capable of supplying 300 MLD. Water started flowing in 1982 from the second stage.

Some aspects of development in water supply as obtained from records in archives are given below.

Where as in the early years tanks (fed by rain water) were used to impound rain water and supply it for irrigation and urban requirements, there was also an early act of draining a tank which in recent years has been accelerated very much. The Domlur tank was used by the military for watering artillery horses. Later on it was converted into an irrigation tank. The tank was polluted by a sewerage canal as early as 1875. The sewer water was diverted to the north-east direction of the tank. (The municipality refused to bear the cost of this improvement stating that the tank was not theirs. So pollution problems have also an old history.) There was a proposal to drain this tank in 1905 itself.

The earliest mention of a water storage system pumping water to the city was in a note in 1885 which suggested collecting the water from the neighbourhood springs of Bangalore in a reservoir and pumping it into the city.

One of the early mentions regarding use of water from Ulsoor lake is in a letter written in the year 1883 by the President of municipal commission to the Resident. This letter relates to the proposal of military not to allow public to use lake water-washing and lifting water from the tank. This is due to the fact that the lake is getting polluted. The President does not agree to the proposal of the military. He also raised a doubt about the ownership of the lake. His contention was that the lake built by Kempe Gowda was not the property of the Madras Government. It was suggested to use police force to control pollution and regulate water use. The Superintendent of Police did not agree to this proposal.

During 1890's, Bangalore city and C & M stations were looking for a new source of water supply. Major grant looked at four sources - (i) Maligal valley,

(ii) Hebbal, (iii) Rachenahalli, and (iv) Hesaraghatta. He favoured the Maligal Valley scheme, but Mr. M. C. Hutchin, Chief Engineer of Mysore, in his report dated May 1893, had shown preference to the Hesaraghatta scheme, because of economics, long-term availability and purity of water. He suggested use of wood-fired boilers and steam engines running the pumps.

The Municipal Commission imposed a water tax with effect from January 1, 1900. The water tax was at the rate of 6% per annum on the annual rental valuation of all buildings and lands in the Civil and Military station. The excess water charges were Rupee 1/1000 gallons of water. The charge for trade was eight annas/1000 gallons of water. Buildings and lands used for military purposes, as places of worship, as public offices and for occupation of persons in the employ of the Secretary of State are exempt from water tax. Charitable institutions were also included in the exemption list in 1903. Bangalore city has a water tax of 3 to 4.5% of annual rental value of a building.

There were difficulties in meeting daily demands due to insufficient storage capacity in Bangalore, there was shortage experienced in the C & M stations. This led to :

- i) restriction of water supply timings to 6-00 a.m. to 11-00 a.m, and 4-00 p.m. to 8-30 p.m.
- ii) free allowance was reduced by 25%.

In 1902, there was a proposal for the supply of unfiltered water for irrigation purposes in the residency grounds. The water was drawn from a well and pumping unit below Queen's Road.

In 1914, there were discussions on the improvements to the Chamarajendra reservoir. The City and C & M Stations were receiving 1.5 m gallons/day of water each and the consumption per day for the city was around 1.15 m gallons. The 1897 agreement between the Government of Mysore and the Secretary State stipulated equal share from Hesaraghatta for both city and C & M station. It was also agreed to have a meeting initially after seven years and later on once in ten years to work out the modalities for increase in water needs. It was thought that Hesaraghatta can supply water to the city and C & M station for a period of 2 years 5 months once full. Its capacity at full level is 747.7 million cubic feet. This was considered adequate because it was felt that a third successive year of draught is unlikely to happen. Eventhough metereological records prove this point, it was found that the rains in the third year might come late. So it was felt desirable to increase the capacity so that a full tank can last for 3 years. It was also shown that there is adequate rain water to fill in the tank at the increased capacity, Similarly, it was felt necessary to increase the storage capacity in the Jewell filters, as its storage was less than one day's requirements of the city and station. These increases are important also from point of view of the increased fluctuations in daily demand. The forecasts for

demands were interesting. The city had a forecast of a stable demand of 1.5 million gallons/day for the next 10 years whereas the C & M station was predicting an increase in demand by 2 lakh gallons/ day for each year leading to a demand of 2.5 million gallons/day at the end of the tenth year.

The year 1918 again saw water shortage in the Civil area necessitating the need for increasing the capacity of Jewell Filters and pumping station at Hebbal. There was even a suggestion of water allowance. It was also proposed to replace steam operated pumps by electrically driven pumps. The steam pumps used wood and it was felt at that time that wood was becoming very scarce and expensive.

A progress report was prepared by Mr. Phelps, C.E. Civil, in 1921 on the works pertaining to a duplicate main from Jewell filters to H.L. reservoir, electrification of the Turbanahally pumping stations and putting up a filtration plant. He wrote on the state of Bangalore's water supply and came to the conclusion that (i) separate supply to C & M station (distinct from the Durbar) was desirable, (ii) the Maligal valley was the obvious catchment area and (iii) the underground water promised to give satisfactory and copious supply. He also found that Mr. Larminie had looked at this problem in 1819 and Major Grant in 1893. They had looked at four schemes- Hesseraghatta lake, Maligal valley, Rachenahalli and Hebbal.

Eventhough Mr. Phelps felt the Maligal valley to be a good solution, he preferred the use of underground water by sinking a 12' shaft below the Jacksundra tank in the valley south of Sankey's tank and driving sideways in the solid rock in order to collect the water held in the various stratas of the plateau. He also mentioned that the necessary skills were available because of the existence of similar work at Kolar Gold Fields (for a different purpose). The reasons for this selection were : (i) the subsoil water is largely independent of rainfall, its rise and fall being only 8' a year; (ii) possibility of establishing a separate system for C and M station ; (iii) novelty of this method (it might prove the salvation of other places besides Bangalore, according to Mr. Phelps), and (iv) filtration may not be necessary. But Major Walsh and Col. Soosbie recommended the Maligal scheme for implementation. Mr. Phelps also considered the possibility of raising the water level of Hesaraghatta lake by 5' to impound more water as another immediate alternative.

In the year 1923, a conference was held to find out the future water needs and to suggest new sources. The system existing at that time consisted of a source- Hesaraghatta reservoir supplying water to Turbanahalli jointly to Bangalore city (under Govt. of Mysore) and C and M station :separating and pumping stations and rising mains upto the common filtering station at Hebbal (jointly owned) ; pumping from Hebbal separately to the respective distribution reservoirs by the pumps of the Mysore Govt. ; distributing individually with C and M station supplying to the military also. Some of the suggestions that came out of the conference were ; (i) Sankey's tank and Hebbal were not acceptable ; (ii) The Maligal valley was recommended. (it was recommended even before the H. scheme was started.) (iii) It was agreed to allow for an increase of 10% per decade in the population. This was

based on the consideration that Bangalore was unsuitable for development as an industrial centre on a large scale. (iv) It was also decided to allow a water consumption/capita of 25 gallons/day. (This was to take care of gardening and water borne sewerage system that had been already introduced.) The percapita figure in 1922 averaged 13 gallons/day and in 1923 it reached 14.6 gallons/day. (v) It was felt that there will be a decrease in the growth rate of population and so the maximum requirement, after 40 years would be around 8 million gallons/day.

The years 1924 and 1925 saw scanty rain falls and consequently there was an expected water shortage in September 1925, the water availability from Hesaraghatta was estimated to last only for two months (even after imposition of restrictions on supply and use of water). By October 8, 1925, the Dodda Tumkur tank was drained into the Hesaraghatta Reservoir, increasing water availability to 4 months. In addition, two more tanks—Kolathur and Madure were breached and drained into the Hesaraghatta Reservoir so that water is available until August 1926. It was agreed to pay compensation to the farmers in these catchment areas against the loss of crops due to non availability of water, the compensation being met jointly by the city and C & M station. But by mid February 1926, it was found that transmission losses were heavier than anticipated. Hence it was felt that the storage will last only until April 1926. The water available in Y tank on Hoskote road was to be reserved and pumped to Bangalore by temporary arrangements. Again compensations were to be paid to the farmers.

A conference held on March 1, 1926 looked at further sources of permanent water supply to supplement that of Hesaraghatta lake. Mr. Sreenivasa Iyengar (First member of the council) suggested that the obvious long term source was the Cauvery river. A short term suggestion was to link Kalkere and Hoovinkere tanks to Y tank as these tanks received a considerable amount of water from April onwards. The municipality was supplying unfiltered water from 9 large wells and ulsoor lake (of the order of 83000 gallons/day) to some large installations and for use on roads. So another suggestion was to open up 14 more wells. Because of the supply of unfiltered water, piped supply was cut off in the following areas : (i) North of railway line, (ii) area bounded in the north by railway line, south by Ulsoor main channel, east by station and west by wheeler road, (iii) area bounded on the north and east by Ulsoor main channel, south and west by land, (iv) Austin town, Vannarpet etc., (v) Akkithimmanahally etc., areas. Detailed estimates had been worked out for the supply of unfiltered water to various areas and uses like railway, schools roads etc.

Other suggestions were (i) to cut off house connections either totally or of only those having wells; (ii) to reduce the hours of supply and (iii) to make use of other sources.

As per the discussions, possibilities were explored for supply of unfiltered water. Actual inspection and survey of all wells showed that there were 2637 wells capable of providing water supply of 1,250,000 gallons/day. But only about 300,000 gallons were being drawn from them daily. Many houses with piped connections did not use any water from their wells. The 62 municipal wells were supplying 171,000 gallons of water. A reservoir was constructed in Gowdanpet, a densely populated area with mill and railway workers, where no wells or street stand post were available. The reservoir was fed with water from a well by a pump and 1500' long pipe line. Taps were provided on the pipe line and the reservoir. Similarly reservoirs were built in Chamarajpet and Cubbonpet; bore wells were becoming popular in Basavanagudi. Reserves were available in Kempambudi tank (to supply to Chamarajpet, Shankarapuram and Basavanagudi areas) and in the bathing ghat (to supply to Malleswaram). All these schemes could substitute for the filtered water supply. Estimates showed that these could supply upto 8 gallons/head/day of water.

The Mysore Government appointed a committee in 1926 to investigate on the Bangalore water supply system with Sir M.V. as chairman. The committee looked for a new source capable of supplying 6-9 million gallons/day of water. Cauvery and Hemavathi rivers were eliminated because of the long distances and heads involved. Hence the Arkavathi valley was identified as a source after considering others like Mutkur tank (below Hosakote tank), Hosakote tank, Yellamallappa chetty tank, Vrishabhavathi valley. The recommended sites were Gavi palya, Giddanahalli and Tippagondanahalli. Thippagondanahalli was chosen based on the consideration of cost and depth of storage. A full reservoir was estimated to supply for 3½ years at 6 million gallons/day and 2½ years at 9 million gallons/day without any inflow at all. The distance was 17 miles from the Combined Jewell Filters. Technical details were prepared by the Committee. This selection was approved by W.P. Smeeth.

Eventhough the T.reservoir water was supplied by the Mysore Government from from 1932-33, it took a few years to sort out the problems of payments and rates of water charges by different groups—municipal commission (charge to military is 12 annas/gallon), military authority and Mysore Government. A conference was held in 1932 to sort out the problems between the municipal commission and the military. One of the problems discussed was what to do with the surplus water if it was not possible to consume a minimum assured quantity of 2 million gallons of water. In order to be totally sure of its reliability, it was also agreed to keep H and Y\* tanks in reserve to be maintained by the Mysore Government. The municipality will meet its part of financial requirements from (a) water tax at 6%, and (b) excess water charges. It was also agreed to buy and install 3000 meters (the number of connections in 1932 was about 4000).

---

\* H means Hesaraghatta and Y means Yellamallappa Chetty tank

The municipal commission proposed to (i) meter all private connections, (ii) to reduce free allowance from 120 gallons/rupee of rent to 80<sup>1</sup> gallons subject to a maximum of 5000 gallons/month, (iii) to levy a charge of 4 annas/month for meter charges, (iv) to charge 12 annas<sup>\*\*</sup>/1000 gallons of consumption in excess of free allowance<sup>2</sup> (v) not to exempt houses occupied by military tenants, (vi) to charge at Re 1/1000 gallons for water consumed for trade purposes, (vii) to consider enhancing the entertainment tax, (viii) to levy a tax on vacant sites and, (ix) to levy a tax on posters and advertisements.

Free allowance given to the employees in the service of the Secretary of State was also withdrawn. There was also a proposal to collect a deposit for excess water charges.

A major problem occurred in 1933 in the Thippegonadanahalli reservoir. It started surplussing from September 20, 1933 and by October 20, a gorge of 40-50' deep cut right through the spillway saddle developed. About 1200 million gallons of water was lost leaving behind 900 m gallons in storage. It was expected that soon hardrock would be met and discharges would stop by November 15, 1933. It was expected that there will not be any serious problem of water availability to city because of stored water in T. reservoir and Hesaraghatta lake (485 m gallons).

Sir. M. Visveswaraiah inspected the breach by mid October 1933. According to Sir. M.V, the mistake was due to the over confidence of engineers on the character of the subsoil and not due to neglect. The engineers had allowed for fifteen feet of ground to be cut away but the floods had actually eaten into the hill to a depth of 45'. According to Sir. M.V., the matter was not important apart from the sensational loss of storage. The harm done and the actual loss to the Govt. were very small.

Immediate construction of earth dam and masonry dam followed by installation of sluice gates were done.

In 1937, a part of the civil and military station was retroceded to the Mysore state and the remainder was formed into a cantonment. A committee was appointed to consider various aspects of water supply to the two areas. It suggested separate water distribution systems to both areas, and on that basis worked out modalities for disconnections of pipes and additions. These would still leave out seven exceptions who should receive water from the other area. A guarantee was built into the agreements for supply of water to Residency by the municipality of the

---

\*\* 16 annas make one rupee

<sup>1</sup>This was later amended to 100 gallons subject to a minimum of 2000 and a maximum of 5000 gallons/month

<sup>2</sup>This was amended to a sliding scale 12 annas, 10 annas and 9 annas/1000 gallons.

retroceded area. The committee also worked out details of costs and payments by respective areas. It also decided that the unfiltered water supplied to seven areas would remain with the cantonment.

In the years 1939-40, there were complaints on water shortage in the north eastern part of Bangalore city—Cooke town, Cox town, Fraser town, Richards town, Campbell road, Muthu karupana palya etc. A door to door survey was conducted to get a first hand knowledge of the problems. Users' complaints were verified later by inspection by the engineer and superintendent. Many of the complaints (about 60%) were found to be correct during the inspection. Hence, it was proposed to improve water supply to this area by the installation of overhead tanks and new pipe lines.

In 1941, there was a dispute between the municipality and Imperial Dairy Institute on the water rates. The Institute said that it should be charged the rates applicable to educational institutions and not the rates for commercial concerns.

The year 1941 saw a shortage in water supply in Bangalore. The water supply was restricted to the hours between 10 a.m. to 4 p.m. daily due to the sudden heavy consumption of water and the inability of the Mysore Government to satisfy "our" requirements.

A localised problem of water shortage (in an area) was brought forth in a letter written to the Resident on November 1, 1943. The letter stated that 300 persons living in Marappa's garden did not have a single tap. The letter went through a long route and finally on March 8, 1944, the Secretary to PWD., Govt. of Mysore sanctioned two taps in that area as a temporary measure for the duration of the war, the water being charged at a rate of Re. 1 per 1000 gallons.

In 1944, the water requirements for the C & M station were studied, analysed and projected to future requirements. The main water supply to the city came from the Tippagondanahalli reservoir on Arkavathi river (after its confluence with Kumadvathi river). It is the responsibility of Mysore Government to supply water from this reservoir to the high grounds reservoir in the city, the distribution being the responsibility of the municipal commission. The quantum of water supplied was 2.5 million gallons / day. It was considered that this is inadequate and there was a need for an additional demand of one million gallons / day due to the heavy influx of troops into the station and the rapid growth of extensions,

An analysis of water supply in 1944 shows that military used 4.5 lakh gallons of water per day, civil populations needs were 2 million gallons / day, transportation used 15000 gallons and industries had requirements of 33500 gallons (Imperial Tobacco needed 19500 gallons. United Breweries 10000 gallons / day and Imperial Dairy 4000 gallons per day). The requirements would increase as follows : Breweries 16000, Tobacco 33500 and dairy 4000, transportation 1 lakh and civil requirements 2.75 to 3 million. Unfiltered water supply was restored to from Ulsoor lake.

Water cut is not a new phenomenon as revealed by the "civil and military station of Bangalore, use of water control order 1945" issued by the Resident in Mysore under the powers conferred on to him by rule 81 of the Defence of India Rules. The main aspects of this order are :

(i) houses are categorised into two groups—those consuming more than 10,000 gallons / month and those consuming between 5000–10,000 gallons / month. The houses in the first category were limited to a consumption of 10,000 gallons / month only. Any excess consumption will be charged at a penal rate of Rs. 15/1000 gallons, (nearly 15 times the normal rate). The houses consuming 5000 to 10,000 gallons of water / month were restricted to 90% of their consumptions, additional consumption being charged at a penal rate of Rs. 5 / 1000 gallons (upto 10,000) and Rs. 15/ 1000 gallons (more than 10,000 gallons of consumption). All houses consuming less than 5000 gallons/month were not affected by this order. (Consumption figures relate to the consumption in February 1945). Institutions were also imposed a cut of 10% and excess consumptions at penal rates might be permitted by the President of the municipal commission.

The president of the municipality, C & M station has proposed to the Resident that (a) filtered water be prohibited from use in gardens (b) water be rationed similar to the rationing of electricity in Madras.

The total savings expected was around 4.2 lakhs gallons per day. But allowing for a few plutocrats who will pay the penal charges rather than sacrifice their gardens, the savings will be 3.5 lakhs gallons/day. The following additional measures were also initiated : (i) Prohibition of use of filtered water by swimming baths or A.R P. tanks, (ii) The executive engineer should pay special attention to overhead tanks and stop all leakages and overflows ; (iii) Sanctioning of an additional watchman to prevent over flows from the overhead tanks ; (iv) The executive engineer

---

#### NOTES :

1. The free allowance of water was given according to the rental values of a building as per a municipal notification in 1899. It starts with 60 gallons for houses with a monthly rental value less than Rs. 12 and goes insteps upto a maximum of 400 gallons for houses with a monthly rental value greater than Rs. 120/-

2. In 1931, there was a suggestion to the municipality to increase water tax. The municipality compared existing water taxes at that time in different cities like Bangalore city, Nasirabad cantonment, Agra cant, Ahmadabad and Mhow cants and found that their tax rate is lower than that of only Agra and Mhow Cantonments. The municipality requested the Govt. of India to sanction a grant-in-aid of Rs. 1,00,000/- per year for a period of three years to meet the deficit in their finances. It also suggested to remove the exemption enjoyed by houses occupied by the military in water tax. (This is despite the Govt. meeting the initial cost of Rs. 50.33 lakhs for a supply of 4 million gallons/day and the municipality had to

should investigate all possibilities of relief by a system of rotation; (v) The executive engineer should submit proposals regarding balancing tanks.

The stringent set of actions normally produce reactions. One such is a request from the tobacco manufacturers (India) Ltd. in March 1945. The letter states that "their water supply has been reduced from 14000 gallons/day to 8000 gallons/day and this will lead to unemployment and reduced production and hence reduced supplies to defence". The letter contained a break up on the use of 14000 gallons of water: Drinking water for 2200 employees is 2200 gallons, boiler feed 6000 gallons, processing needs 5200 gallons and humidification 600 gallons.

The penal charges proposed in water control act brought forth another letter from M/s Higgin Bothams protesting loyally against penal charges. They have analysed per capita water consumption and shown that they are economising on the use of water. Another protest on the penalty fees came from the southern division rate payers association in July 1945. This resulted in an addition to the water control order. "No house which consumed 5000 gallons or less during the relevant period shall consume more than 5000 gallons a month".

In 1945, there was also a discussion regarding the sharing of 3 million gallons of water supplied/day between military and civil uses. The military use was increasing from 3 to 5.8 lakh gallons/day, the extra emergency capacity being only 1 lakh gallons/day.

A letter issued by the HQ Southern command in February 1946 on water shortage wanted that the watering of floor gardens at Jalahalli must cease. This decision was not taken lightly—taken with the knowledge of the amount of labour gone into the planning of these gardens. A part of Binny Mills was closed down due to the shortage of water supply. In order to restart gardening at a later date, maintenance of a nursery for seedlings was proposed. The above condition was not applied to the vegetable gardens. Flower gardens should not be converted to vegetable gardens.

---

**NOTES :**

meet their share of recurring cost of 3.5 lakhs of rupees/year). There was a suggestion from the Govt. that it is possible to meet the financial requirements by (1) installing meters; (ii) reducing free allowance; (iii) levying water tax on government buildings as well as contributions from municipality and a small balance of Rs. 26,000/- to be met by the Government.

3. There was also another problem raised in 1931 that of sharing the cost of water supply between military and C and M station (municipality). The 1897 agreement stipulated allotment of two thirds of the expenditure to the C and M station and one third to the military. But a study of population in 1930-31 showed that civil population was 1,34,123 and military population was 9,673. Consumption of water by civilians was 514 million (91%) and by military was 51 million gallons (9%). Based on this the government directed that the cost sharing should be on the basis of actual consumptions.

### **Bangalore Water Supply System.**

Water supply to Bangalore city is handled by Bangalore Water Supply and Sewerage Board (BWSSB). BWSSB is organised into two divisions, and seven sub-divisions. Each sub-division has many service stations. There are about 30 Service Stations. These handle water distribution in the city. Appendix I lists the units of BWSSB.

Table 2 gives water available per capita over a number of years. The value is mostly around 10 gallons/day except for some sudden spurts. Table 3 gives water inflow into Bangalore from the three sources. Table 4 gives projection of water supply from Cauvery. Some salient details of our water supply system are given in table 5. We can see that energy plays a very significant role in water supply. A look at the expenditure shows that 48% of revenue goes to meet the energy expenditure. Unit cost of water per 1000 litres was 75 paise before Cauvery I stage implementation. It increased to Rs. 1.35 after the stage and to Rs. 2.35 after the completion of second stage. It is expected to go to Rs. 4 to Rs. 6 to after the III stage.

Since our main intention is to see the impact of water on our urban ecosystem and conversely the effects of the growth of the city on water, we are not concerned here with various technical aspects of water distribution like design of reservoirs, pump houses, pipe lines and net works, filter beds etc. BWSSB is handling the technical activities in a very able manner and our work is to complement their activities.

The next section deals with our methodologies in conducting this study.

---

### **NOTES :**

4. Consequent to the decision to augment water supply with Thippegonadahalli, a new agreement was signed between the Secretary of State and the municipal commission in 1931. The main parts of this agreement are ; (a) maintenance and control of the distribution will be with the Govt. of India, (b) the municipality will pay a share towards the expenses, (c) the monthly cost of maintenance should be calculated as one twelfth of the amount made up as follows-  $2\frac{1}{2}\%$  on the cost of pipes plus 2% on the cost of works and buildings, (d) this agreement will remain in force for a period of five years.

5. It was agreed in 1931 to keep Y and H tanks as stand by (in the case of failure of T. reservoir) and pay to the Mysore Govt. water charges at the same rate as applicable to T. reservoir.

6. In 1934, the water charges were 7.65 to 7.38 annas / 1000 gallons of supply to be paid to the Government and the public were charged as follows : Educational institutions at the rate of 8 annas per 1000 gallons, charitable institutions at the normal rate after a free allowance of 6 gallons / head / day, religious institutions to pay 4 annas / 1000 gallons, cemeteries to have free water supply, choultries to have a public stand post. (The charges have not proportionately increased with time.)

#### **4. Methodologies,**

BWSSB maintains excellent records regarding water consumption for domestic and other purposes in every service station. This forms our base for further data collections and analysis. This involved the following steps :

(i) collection of data from BWSSB.

(ii) a preliminary study of the data revealed that we can obtain percentage consumptions in each service station and for each category.

(iii) further, domestic consumptions dispersal can be looked at by analysing consumption / connection. This index (water consumption for each connection) is considered better because the number of connections varies from service station to service station.

(iv) because of the availability of data for three years, it is possible to look at growth rates. Growth rates for water consumption were calculated for all subdivisions (and service stations). These are absolute growth rates. They do not take into account changes in the number of connections.

(v) hence, growth rates of consumption / connection were calculated to provide a realistic picture.

(vi) even these growth rates for per connection situation do not reveal an accurate picture regarding usage. This is due to the fact that the number of persons/connection varies. Hence it was felt that per capita consumption is a good indicator.

But getting population figures for each service station is not easy. Population statistics is available for each corporation division. But unfortunately, the boundaries of corporation divisions and BWSSB service stations do not match. Hence it is not possible to get directly per capita consumption.

Initially, the boundaries of BWSSB service stations and corporation divisions were obtained. They were marked on a large map of Bangalore city. From the population figures available, population for each service station was calculated. Whenever a corporation division fell in the domain of two service stations, it was assumed that population is proportional to area and based on that assumption, population for each service station was assigned. In this manner, we calculated population in each service station. This is the first time that an estimate has been made. This can now make it possible to study at service station level per capita consumptions.

It would have been nicer if all public utilities like Electricity boards, Water boards, Marketing Organizations etc. and municipal/corporation bodies have the same area, sub-area, division and other groupings. Then it is possible to analyse the impact of various economic activities. This gives decision makers a tool to identify problem areas and thereby attend to them immediately.

Towards this, we have obtained the population figures for each service station. We would like to get other economic parameters also in a similar manner so as to study the linkage between water use and economic parameters like income.

Once we have calculated the populations, it is possible to obtain per capita consumptions and analyse them.

Similarly case studies were conducted for water consumption in some industries, in fountains and in slums.

## 5. Consumption Analysis.

### 5.1 Consumptions in each sub-division

Tables 6,7 and 8 give consumption of water for domestic, non-domestic, industrial, public fountains and other purposes in the seven subdivisions for the years 1981, 1982 and 1983 respectively. These were got from the primary data collected from the service stations for every month for these three years and presented after accumulation for the whole year and for each subdivision. Water consumption is stated in million litres/day.

Table 8 has been analysed further. It can be seen that

(i) Percentage consumption of subdivisions vary from a minimum of 5.55% to a maximum of 22.72%. Surprisingly, three old areas of the city (Malleswaram and Sriramapuram, Chamarajpet, Basavanagudi, Visveswarapuram, and Mount Joy; and Ulsoor areas) have higher consumptions (19.37%, 22.72% and 19.78% respectively).

(ii) Percentage consumption, sectorwise, shows that domestic use is 56.8% and public fountains use is 23.3%. Both put together consume 78.1% of total water used in the city. This means that domestic use still enjoys primacy in water distribution. This is also an essential fact worthwhile remembering at the time of suggesting proper water conservation methods. Non-domestic use comes next with a figure of 12.9%.

Lowest consumption of public fountain figures is for sub-division 5 (Jayanagar etc). The highest is for the seventh sub-division (Rajajinagar, West of Chord Road). But if we consider the ratio of consumption by Public Fountains to that of domestic use, we get the following figures :

Sub-division No.	Ratio
3	0.6199
7	0.5587
4	0.5313

This shows that in the third sub-division, relative consumption by public fountains is the largest (62% of domestic use). This is followed by seventh and fourth sub-divisions.

Table 9 gives percentage consumptions. It has been derived from Table 8. From this, we can see that (i) Except for first and third sub-divisions, all other sub-divisions have domestic consumers using more than 50% of water used.

(ii) Non-domestic use is maximum (percentage-wise) in the third sub-division.

## **5.2. Consumption / Connection :**

We saw a picture of absolute consumptions and where the water goes in the previous section. In order to understand the problems at consumer end, another index was chosen. This is consumption / connection. This becomes meaningful especially for domestic consumers. Table 10 gives the number of connections for each category in each sub-division. This is again the averaged value for the year 1983. This has been chosen for purposes of further analysis instead of the values at the end of year 1983. The number of domestic connections per sub-division varies from a minimum of 14,420 for the third to a maximum of 26,519 for the sixth sub-divisions.

Tables 8 and 10 are used together to get the average consumption / connection. This is given in table 11. Here, the average is given in kilolitres / month. The average for domestic consumers varies from a minimum of 20.36 (s.d. No.2) to a maximum of 40.39 (s.d. No. 4). The average consumption / connection for all sub-divisions is 27.53 (for domestic). Only two sub-divisions are above this average. Three sub-divisions are close to this value. The remaining two (2,7) are below this average.

The averages vary considerably for public fountains from a minimum of 385.61 to a maximum of 1370.

It is assumed that this index does not reveal anything about non-domestic consumers except their diversity. But the values quoted for non-domestic in Table 11 reveal that the variation is from 77.57 to 159.2 and this is very much similar to the variations for domestic case. Hence, average diversity of usage within a group is similar among non-domestic and domestic consumers.

To look at intra sub-division level, domestic consumption / connection varies from a minimum of 15.45 kl / month to a maximum of 53.79 kl / month, the diversity being larger than the subdivisional level variations. This means there is a maximum variation of 3.48 times in the water use/connection for domestic purposes amongst service stations.

Let us next consider growth rates in consumption and consumption/connection.

## **5.3 Growth rate in consumption :**

From the available statistics for 1981, 1982 and 1983, it is possible to calculate percentage growths for each category for every service station. This has been done for all subdivisions except the fifth one. Table 12 gives the growth in consumptions. From this table, we can see that

(i) The growth can be positive or negative ;

(ii) For domestic consumption, the rate varies from 13.27% to 19.48% in 1981-82 and from -41.77% to 111.35% in 1982-83;

(iii) Large variations are found in non-domestic, public fountains and industries sectors also.

#### **5.4 Growth rate in consumption/connection :**

Table 13 gives the computed values for growth rates for each service station excluding subdivision No. 5. This index will reveal intra consumer growth and hence has been calculated. Declines may also be due to insufficient water supply.

If we consider domestic consumption, we can see that the growth rate varies from -21.38% to 16.31% in 1981-82. Five service stations have large negative growth rates ; three of them have a positive rate greater than 10% nine have positive growth rates (less than 10%); four have small negative growth rates (greater than 10% but less than 0%).

Whereas, the growth rates for 1982-83 show a greater diversity-variations ranging from (-36.07% to 106%). Ten of the service stations have negative growths and the remaining eleven have positive values. Subdivision 4 has shown remarkable growth rates - all but one service station have growth rates greater than 60%. Subdivision No. 7 has all negative growths.

In the case of public fountains in 1982-83 period, ten service stations have negative growths, four of them being from the sixth subdivision (which has shown good growth rates in the domestic sector). This shows that improved domestic supply reduces dependence on public fountains.

#### **5.5. Per capita consumption :**

Since the number of persons/connection might vary (in some places many flats may be treated as one connection), another alternative index chosen was per capita consumption. In this case, we obtain the population for each service station (including those people who do not have a connection). This population is obtained by processing census data. Based on this, per capita consumption has been calculated as given in table 14.

The maximum consumption is 119.5 litres/day; the minimum being 20.04. (Variations being of the order of 6:1) The service stations have been categorised according to consumption. The corresponding frequency distribution is given in table 15. We can see that the average consumption is 48.24 litres/day. Sixteen out of 28 service stations have per capita consumptions less than the average. Five stations have a large consumption (greater than 90 litres/day),

Table 16 gives the category wise distribution based on water consumption. This shows that 60% of the service stations consume 53% of domestic water. Distributions between service stations and consumptions are nearly similar.

In order to see the effect of population, table 17 has been prepared. This gives percentage and cumulative percentage of population covered by different categories. The population consuming water less than the average percapita is 68.97%. We also see that 11.29% of population consume 24.41% of water consumed. (belonging to category 8). Also 21.93% of population (categories 5 and 8) consume 39.2% of domestic water.

At the other end we see that 14.83% of population consume 7.45% of water (belonging to category 1). Categories 1 and 2 constitute 50% of population, but consume 35.48% of total domestic water.

The above observations have been drawn on the basis of the analysis on data linking population and water consumption. It is desirable to conduct further analysis to get (i) water distribution amongst piped and non-piped consumers, and (ii) distribution amongst various categories of piped consumers.

#### **5.6. Monthly variations in consumption :**

Since the city gets its water supply from two sources—getting their monsoons in different seasons—it is desirable to see whether there are any monthly variations in water consumption. This can be measured by getting the average monthly consumption and the standard deviation of these consumptions. Table 8a gives the average monthly consumptions (in kilolitres) and the standard deviations for most of the service stations for the year 1981, 1982 and 1983 (1983 and 1984 in the case of the fifth sub-division) Larger values of standard deviations suggest large variations in monthly consumptions. This information can be used in planning month by month water supply-demand balancing activities for all service stations.

Table 8a reveals the following information :

- (i) In 1981, the maximum standard deviation was 15.15% (for Ulsoor service station). In general, the sub division containing Ulsoor, Indiranagar, J. B. Nagar, C. L. R. and Machalibetta has shown a high diversity figure. Nine service stations out of a total of 21 stations, have standard deviations greater than 8%.
- (ii) The year 1982 records a maximum S. D. of 48.2% (again for Ulsoor service station.)
- (iii) In the year 1983, the maximum S. D. was 45.89% (for Gangenahalli service station). The S. D. for Ulsoor came down to 6.25%. The reason for this change is not known. 16 service stations out of a total of 28 have got a S. D. which is greater than 8%.

The variations in standard deviation may be due to a high rate of growth also. In order to see whether the variations are due to seasonal effects-monthly variations-

or due to growth, table 8(b) is derived. This table contains two parameters for the years 1981, 1982 and 1983. These two parameters are-average percentage growth of water consumption in each service station ; the number of months with negative growth rates.

Let us first look at the percentage growths for various service stations. The maximum growth rate in the year 1981 was 4.662%. Only 8 service stations showed positive growth value ; even these growth rates were small.

But the second parameter is more revealing. The table gives the abstracts of monthly growth rates. The number of negative monthly growth rates and the total number of growth rates are given. That is, 5/11 means that five values out of 11 are negative. A general look at table 8-b shows that the number negative growth values varies from 25% to 67% of the total number of growth rate values. (only in the case of Mount Joy in the year 1983, there were no observed negative growth values). This shows that there is a seasonal variation in water demands in many service stations

The distributor-BWSSB-can take advantage of these seasonal variations in the weekly planning activities. In the beginning of a year or a quarter, one can plan weekly water demand-supply balance so that we can predict smaller scarcity problems and undertake preventive measures-like rerouting of water amongst service stations-so that we can move towards equitable distribution amongst service stations. These variations play an important role when we consider alternate water supply sources like rain water harvesting, use of waste waters etc ; then this activity of planning weekly demand supply balance becomes important and necessary. This activity will also decide on changes in the capacity of temporary storage reservoirs. This also leads to economy of operations.

Our analysis of seasonal variations are restricted to the domestic sector only. It is desirable to conduct similar analyses for non-domestic and industrial sectors also.

#### **5.7. Distribution of pipelines amongst sub-divisions :**

Table 18 gives the distribution of the length of pipelines amongst various sub-divisions. The length of trunk pipes per sub division varies from 14.8 kilometres to 30.8 kilometres. Similar variations can be seen in feeder pipes from 19.1 kilometres to 105.6 kilometres, in sub-feeder as well as distribution pipes. The total pipe line length is 1856.8 Kilometres.

#### **5.8. Energy Charges**

Table 18 (a) gives the power consumption details by pumps in the transmission system. The total maximum demand is 29.84 MVA in 1984 and contracted demand is 33.84 MVA. Energy consumed was 16.17 million units/month. Load factor is about 80%. Energy charges are around Rs. 60 lakhs/month. An estimate shows that the pumping units in house connections will have an installed capacity of 50-75 MVA and will consume energy about 30-45 lakh untis/month. Inclusion of

non domestic and industrial sectors increases both these quantities to higher values. It looks like that people are spending as much for energy consumptions to lift water from their sumps to over head tanks as spent by BWSSB.

The results of the distribution of water consumption, storage capacities and pipe lengths amongst various sub-divisions show that there is a need for rational realignment of sub-divisions. As already suggested earlier, it is desirable to have a uniform policy of demarkation of divisions by various bodies like B.W.S.S.B., K.E.B., B.T.S., Corporation, etc. An integrated approach to the development of various services, utilities and other amenities to each of these divisions on a de-coupled manner is important to see that a city does not get over crowded leading to explosive situations.

The next section discusses the case studies on the water consumption by industries, public fountains and slums.

#### **6. Cases studies of water consumption in industries :**

In order to understand the uses of water for various purposes, case studies were conducted in chosen places—industries, public fountains etc. The analyses pertaining to some of them are given below.

##### **6.1. Bangalore dairy :**

Observations, measurements and calculations were conducted in December 1983. The dairy was producing about 90 tons of butter / month, 90 tons of clarified butter / month, 120 tons of butter milk/month and 220,000 litres of milk/day and small quantities of peda in addition to milk powder (50 tons/month) and flavoured milk.

The dairy gets its water from BWSSB and stores this in tanks. The average daily consumption is around 750,000 litres. The distribution of this for various types of uses was measured and calculated. Table 19 gives this distribution. Major use is for washing and cleaning the floor. 36.5% of water use is for washing and cleaning ; 23.3% for floor cleaning. It is possible to use recycled water for this purpose. It is shown that 74% of water used is biodegradable. After treatment, this water can be recycled for use in the washing and cleaning activities.

Calculations of water required/Kg of milk show that this figure varies from 2.59, 2.90 for winter months to 5.02, 5.59 for summer months for the year 1983.

##### **6.2. Vitaz Food Products Pvt. Ltd.**

This factory produces 1 tonne of biscutts/day. They get their total water requirements from BWSSB. The water consumption is given below category wise.

Process water	120 Litres / day (12.5%)
Cleaning of machines	30 Litres / day
Cleaning of hands of workers etc.,	160 Litres / day

Washing the vans	350 litres / day
Toilets	200 litres / day
Gardening	100 liters / day (10.4%)
Total	<u>960 litres / day</u>

From the above, we can see that a large percentage (more than 80%) of water need not be of a high quality or purity.

### 6.3. Premier Asbestos Cement Products

This is a small industry making cement asbestos pipes and other cement products. The water source is BWSSB. The factory recirculated water used for curing and cooling purposes. So the water usage is as follows :

Production use	625 litres / day ( 9.4%)
Curing use (make up)	5,000 litres / day (75.5%)
Human consumption	1,000 litres / day (15.1%)

### 6.4. Small Industries

A bakery in Malleswaram was surveyed. It consumes 240 litres/day-out of which 100 litres is used for the preparation of products and drinking purposes. 140 litres is used for washing purposes.

Two studios surveyed did not have any taps and water is brought to them from outside and hence their use of water is restricted to 20 and 40 litres/day. (mainly for processing only.) This is equal to nearly half a litre of water per print (of photograph).

There are six swimming pools in Bangalore, four of them are of international standard. They need 7.86 lakh gallons of water. Water is recirculated and changed once a year. Water consumed for bathing and toilets varies from 1500 litres/day in winter to 9000 litres/day in summer.

### 6.5. Study of water consumption for cleaning of vehicles in Bangalore :

A service station was surveyed by us. The following estimates for water consumption was got for different vehicles based on measurements.

Cars	300 Litres
Two wheelers	150 Litres
Lorries	1,800 Litres

Using the above norms, water required to clean all vehicles in Bangalore East, South and West was computed as per table 20. About 612.9 lakh litres of water are used to clean all vehicles once. If we assume that each vehicle is cleaned once a week, the per day water consumption works out to 8.75 million litres.

These studies clearly show that it is possible to conserve water and use impure/ recycled water for floor washing. Development of miniponds by industries for their use for washing, cleaning and cooling purposes will reduce water consumption considerably. In addition, the surrounding environment will look better, cleaner and cooler. In many industries, space is available to build mini ponds. In cases of small scale industries, it is possible to build such ponds in industrial estates. Annexure IV gives water consumption in some more industries.

#### **6.6. Analysis of water use in public fountains (taps) :**

As per the data available from BWSSB, public fountains consumed 23.3% of water in 1983 (57.9 million litres / day), the variations being from 11.85% in subdivision 5 to 32.1 in subdivision 7 (Table 21). Because of their importance, a few public fountains were surveyed. Water use by various families, timings of water availability, possible maximum quanta of water / day and actual consumption were measured. A simple method—time taken to fill a bucket of 10 litres—was used to measure the water pressures at different locations. Table 21 gives the water consumption at different locations.

The number of houses using a public fountain varies from 6 to 62, the population varying from 40/ Public Fountain to 428/ Public Fountain—a variation of 10 times in both. The data pertaining to the quantity of consumption / day show a minimum of 430 and a maximum of 13,975 litres / day. The maximum distance travelled is 360' one way. Hours of supply each day varies from 2 hours to 24 hours. The maximum pressure of water is given by 23.9 seconds/10 litres and the minimum pressure is 165 seconds/19 litres.

The per capita consumption is the correct index to study the disparities amongst the sampled public fountains. The minimum is 10.75 litres / day / person and the maximum is 76.8 litres / day / person (Table 22). There is a good correlation between this and water pressure. Another feature seems to be that in some public fountains a few families dominate the water usage. The maximum possible per capita water availability in each P. F. has also been calculated based on the water pressure, hours of supply and the population using the P. F. It also varies from 11.00 litres / day to 111.00 litres / day. These factors show that in some cases, there is a need for another public fountain. In some cases like Ulsoor, people supplement the P. F. water with well water. Comparison of water use by middle class and by people in slums shows that water consumption is decided by one's life style and cultural beliefs (like bathing). Whereas these people take bath everyday, people surveyed in slums take bath once a week.

Since the surveys on public fountains were not conducted over a large time span, there is a possibility of variations in the consumption patterns in different months.

### **6.7. Water consumption in slums :**

Five slums were chosen at random in different locations for the study of their water consumption. In each slum, a sample of house holds was chosen for the purposes of survey. Table 23 gives the information pertaining to these slums. Average per capita consumption varies from 16 to 23 litres / day. Only one slum gets its water from wells, others being serviced by Public Fountains. This difference in source does not affect their consumption patterns. Also abundancs of supply does not increase the consumptions. This is true especially in the case of slum No. 4. Despite there being 3 public fountains and other supplies in the service station, the consumption is only 18.33 litres / day / capita. Comparing this with the table on public fountains reveals that there is a large difference in per capita values between these two groups. Life styles like bathing and washing frequencies were found to be the same in all these five slums.

## **7. Alternate Sources of Water Supply**

We have been currently dependent on rivers as the main source of water supply. This has created certain limitations in the growth of water supply to Bangalore City. Some of the limitations are : (1) the contentions in the use of water for city and irrigation have been increasing ; whenever the command areas have developed, the residual water available for city use reduces considerably. This is happening even now with the water supply from the Arkavathy source decreasing considerably with time. The deficit between the estimated supply and the available supply is increasing every year. (ii) Since one of the major sources-Cauvery-is at the lower level, we have to pump water over a very high head of about 1500'. This needs a large amount of power. Hence the reason for a major part of expenditure going towards meeting the energy charges. So it is desirable to look at alternate sources. These sources are : (i) Water conservation and economy, (ii) rain water harvesting, (iii) water recyling, and (iv) ground water tapping. These are discussed in the succeeding sections.

### **7.1. Water conservation :**

This is an indirect source ; by reducing water content in many processes and activities, we can reduce our water requirements. This has been shown clearly in the previous section. One example is the washing of vehicles-most of the water reaches the ground and goes as waste. Instead washing in a small pond will help in recycling the water and thereby reducing water consumption / vehicle. Another example is the use of water for cooling purposes. Many industries and organisations like Indian Institute of Science use water as a coolant to cool their devices or processes or products or in the preparation of distilled water or other products. It has been observed that many of these are open ended systems, that is water is taken from source and discarded after flowing through coolant pipes. Conversion of these open ended systems to closed loop systems will avoid water wastage. This

will bring down our water requirements considerably. Many chemical laboratories and industries use water for this purpose and a suitable redesign can reduce water consumption.

## **7.2. Rain water source :**

The second alternative is the tapping of rain waters. Rain water has been the main source of water supply for many cities. (Example Bombay city) Rain water has been used by storing it in lakes and reservoirs. Because the rain water will stagnate in many places, normally drainage systems with open drains are provided in every locality. We see these drains in every street. Earlier days saw a well developed network of drains taking the water to a lake or reservoir in the neighbourhood by gravity. The lake will be situated in a low lying area. Cities like Bombay get their water supply even today from lakes supplied by rain water only. This has many advantages like :

- (i) Since rain water should not stagnate in houses or streets, drains are a necessary part of a layout. So collection of rain water is not a problem. We need to augment our network of drains and maintain them properly.
- (ii) The existence of lakes increases the recharging of ground waters. Because most of the roads are asphalted in Bombay, a good portion of the rain water flows into the sea (a part of it has to be pumped into the sea during heavy floods). This is a wastage. Proper harvesting will increase ground water potential.
- (iii) The existence of lakes increases the area under open space in a dense city and improves the urban environment remarkably. Children find a place to play ; older persons can walk ; trees can be cultivated on the periphery ; population of birds can be increased ; fresh pollution free atmosphere is available ; recreation facilities can be introduced ; and so on.
- (iv) Currently, during a high intensity rainfall, roads get flooded. (example : Chickpet) This is due to the clogging of drains, insufficient size and number of drains and non-maintenance of drains. This can be avoided if there is a provision in each locality for a lake into which these waters can be led.
- (v) Similarly, a large portion of rain water gets into the sewerage system. This means that city's sewerage system should be designed to carry not only the waste water from users, but also a part of the rain waters. Firstly, such a design increases the cost of the sewerage system. Secondly, the system will not cope with a heavy rain fall resulting in overflows from sewers onto the roads and houses. Thirdly, these waters may enter a water supply pipe nearby (a very small probability) thereby creating health problems. Hence proper design and maintenance of rain water collection and storage will reduce the load, cost and inconvenience on the sewerage system.

- (vi) Certain activities in the city like washing of clothes by washermen, washing of vehicles and animals etc. can be undertaken in a controlled manner (by installing washing stalls) thereby reducing water requirements for these activities.
- (vii) The cost of maintenance of a lake is low. Also let us consider the cost of land and annual charges due to the cost of the land required for a lake. Assuming we pay this as a rental to the city corporation, if we calculate the cost of water from this lake, it works out to be less than the cost of water supply from Cauvery. So even the consideration of economics of running costs is in favour of rain water supply to Bangalore City.
- (viii) Similarly, capital costs are lower compared to capital costs for supply from Cauvery or other rivers.

Some of the disadvantages are : (i) use of urban land (this is not a disadvantage for Bangalore City); (ii) upkeep and maintenance to reduce (a) waste waters getting into the lakes and (b) unhygienic conditions on the shores and the neighbourhood of the lakes ; (iii) mosquitoes production.

These disadvantages can be removed by proper upkeep and maintenance of the shores and neighbourhood, provision of good toilet facilities and if necessary, pollution treatment facilities to treat waste waters flowing into the lakes, maintenance of drainage system, and control of mosquitoes.

Because of these advantages, it is essential that we should go in for taking up seriously rain water harvesting work for meeting our water requirements atleast partially.

### **7.3. Rain water potential**

Before we can tap rain water, we should know the potential of rain water available in Bangalore city. There is no point in discussing this alternative if there is no sufficient potential available in the city.

In order to estimate the potential, we collected rainfall data for the past sixty years. Table 24 gives the annual rainfall data in millimeters/year. From this table, we can see that the minimum rainfall in Bangalore City is 587.8 mm/year. Using this figure and collection efficiencies, we can calculate available water supply from rain water in Bangalore city. The water quantity works out to about 45000 million litres. This means that if we assume the current demand to be 400 million litres/day for the city, about 30.8% of this demand can be met by rain water harvesting alone.

Rain water in Bangalore city is widespread for many months in a year even though a major portion comes in August-September.

#### **7.4. Rainwater harvesting**

As already seen, the rain water pertaining to Bangalore City has the following characteristics.

- (i) It has a potential to meet about 30% of our needs.
- (ii) It can also be a complement to Cauvery water supply, since major rains come late (Aug-Sept) to the city and early (June-July) to the cauvery catchment.
- (iii) No pumping over high heads (of 1500'-2000') is needed.

Rain water harvesting needs drains small and large in every street and area followed by a storage unit like a lake. There are two ways of designing the storage reservoirs ; one to design a reservoir with a capacity to meet the entire year's requirements : and the second way to design it to meet the requirements for a partial period.

In the second method, the reservoir will become dry for some months in a year. Since, rain water is meeting only partly the cities' requirements, the storage capacity can be calculated so as to meet the needs of the city for a part of the year and not the full year. This will reduce the area required for a reservoir—an advantage in a city with a premium on land cost. The water supply from rain water and rivers can be distributed in a complementary manner throughout the year.

From the point of view of economics also, it can be seen that the cost of water / kilo litre is less for rain water than for water from the cauvery river. This costing includes the cost of land as per BDA rates. Unfortunately, the reverse is happening in Bangalore—existing tanks and reservoirs have disappeared and are disappearing very fast. One of the reasons stated by BDA for breaching the tanks is the pollution of the waters by the inflow of sewerage water. Even in newer areas, tank areas are converted into sites for buildings by BDA. Blocking of inlets to reservoirs is the first activity which reduces the inflow. Consequently, the water storage reduces considerably leaving a part of land exposed. This land area is taken over for development and the lake is shrunk. In this manner, a lake is slowly killed.

Let us see the rate of destruction of tanks. Table 25 illustrates this. In 1931, there were 114 tanks in BDA area and the number reduces to 11 in 1981. Table 26 lists the names of about 103 lakes present in 1931 and their status in 1981. We can see that many tanks have disappeared in our living time itself. Many of us have seen these tanks with water about 10–20 years ago and dry now. It is imperative to reverse this trend now. This calls for the following actions ,

- (i) Conversion of tanks into building sites by BDA or BMRDA should be banned immediately.
- (ii) The existing tanks should be inspected, encroached areas to be vacated and all inlets should be rebuilt and augmented,

- (iii) A maintenance wing should be created and entrusted with the work of cleaning and maintaining drains and the lakes / tanks.
- (iv) The now defunct tanks (Table 26) should be inspected and wherever possible, they should be rejuvenated. (even on a smaller scale and after deepening the lake area).
- (v) Fortunately, the government has declared a green belt around the city. In this area, it is possible to identify a large number of suitable sites (areas) for the identification and construction of new tanks. Funds for this can also be obtained from NREP and similar employment generation programmes in addition to other sources. Industries, institutions and public can be encouraged to participate in this financially. Rotary and other organizations and NSS of Universities can also be used for this work. (NSS means National Service Scheme)
- (vi) It is also desirable to have a secondary level of reservoirs developed in the areas outside green belt also. A look at the map of Bangalore district shows that there are a large number of slopes and valleys and undulations in many places—ideal choices for location of tanks. Land use plans for new extensions should include areas for lakes.
- (vii) Many industrial estates have large areas. For example, the Peenya industrial estate has an industrial area of nearly 7 square kilometers and a total area of 25 sq. kms. Such large areas should be allowed, encouraged and pressurised to start a rain water harvesting scheme. They can build a reservoir and construct drains leading to it. Similarly, there are many industries and organizations having large areas (like Indian Institute of Science, Indian Institute of Management, Defence Establishments, HAL, HMT, BEL, etc). It is desirable to start co-operatives in each area to tap their rain water and supply it to the industries and households. Water distribution is not a total monopoly of the State unlike electricity distribution. Hence, the government should suggest to these organizations, industries, industrial estates and also housing colonies to take up water supply co-operatives based on rain water (and also waste water as discussed in the next section).
- (viii) Allow the use of a lake for other purposes like boating, swimming, fishing, recreation etc. So that it becomes an income generator like in Bombay.

Two main reasons why tanks are breached in the newly developing metropolitan area are :

- (i) value of land—land occupied by a tank can be put to use for various purposes like construction of a bus stand or stadium or buildings;

- (ii) pollution of tanks by the inflow of sewerage waters. This problem, though occurring for many years repeatedly, is solvable through sustained efforts, and public education programmes. One example that comes to our mind is the cleaning of Kukkerahalli tank in Mysore by NSS volunteers of the University. An interesting solution found by them to solve the problem was to segregate this lake into two parts—allowing the sewerage water to flow into one part and maintaining the other section clean. The effort required for maintenance was reduced by this process.

These two problems are solvable. Consider the example of Ulsoor lake (public campaign by Rotary to clean this lake). The problem of disappearance of tanks pertains to Bangalore Metropolitan area only. The number of tanks in Bangalore district in 1969-70 was 1565 and 1848 in 1981-82. This shows that there is no reduction in the number of tanks in the district.

Let us now consider waste water treatment and recycling as another alternative.

#### **7.5. Waste Water Treatment and Recycling :**

Every city does not consume the entire water supplied to it. Estimates show that about 20% of the input water is consumed and the remaining 80% is let off as waste water. The sources of waste waters are domestic, commercial and industrial. The "disposal" of waste waters poses a problem to the administration. They pollute the water sources hence they cannot be let directly into water sources like streams or canals or lakes. The waste water must be treated before being let into a stream or lake. The State Pollution Control Board estimates that domestic wastes from cities create a major pollution problem to the rivers of Karnataka.

Since (i) 80 of water supplied to a city becomes 'waste' and (ii) it is imperative, according to our existing acts, to treat it before it joins a 'main stream', the waste water becomes an ideal source of water for many applications like washing, cooling, cleaning, curing of buildings under construction, etc. These applications or end uses also make a major demand on a city's water supply as can be seen from our case studies (Section 6).

The estimated availability of waste water for Bangalore city is given in Table 27 (a total of 756 MLD after the third stage) BWSSB has plans to treat these waters in the different valleys. These treated waters will be creating huge reservoirs in the neighbourhood of these valleys and so it is desirable to reuse them. Reuse of waste waters is not a new phenomenon and technology for treatment as well as expertise to design and operate waste water reuse systems are available in our country and in our city itself. Appendix II gives some examples of use of waste waters.

Table 28 gives a list of industries in Bangalore district who are treating their waste waters for use. This information was obtained from the State Pollution Control Board. Twenty industries are treating their waters—both trade and

domestic wastes. The total quantity of water treated is about 4.8 million litres per day. Senapathy Whitelay Ltd., treats its waste water (about 2.1 mld) and supplies it for irrigation purposes to the neighbouring area in Ramanagaram taluk. Recently, many other industries like HAL have started treating their waste waters.

Table 29 lists some major industrial consumers of water and their water output capacities. About 25 million litres per day can be got from these 26 industries. This is about 8% of the total supply to the city. A large amount of the water can be used directly by the industries themselves thereby minimising the piping costs.

In addition, many industrial estates can also take up jointly with BWSSB treating their waste waters and using them again. Such activities for collective waste water treatment systems for industrial estates have been initiated in cities like Bombay. Since an industrial estate has many problems common to its industrialist members, it is ideal and feasible to include the problem of waste water treatment and water supply also to this list of common infrastructure problems. We have a number of eminent environmental engineers in the Bangalore city, some of them like Dorai and Sesh undertaking a large number of integrated turn key projects for area or town planning including waste water treatment and drinking water supply and treatment systems. Hence not only technology exists and applied to many areas, but also integrated systems engineering approaches and plans are also available and applied to practical problems and new townships. In the case of large sewerage treatment systems, we can get biogas (methane and carbon dioxide) as a by product through anaerobic digestion which can be used as an energy source.\* Estimates of power potential from Bangalore's sewerage water are around 10 MW to 20MW at 50% load factor. Appendix III gives a case study for Peenya industrial area. It shows that the investment required for a recycling system is very small compared to the investments made on the industries and the cost/kilo litre of recycled water compares favourably with the cost of BWSSB water. If we consider the current cost of water from Cauvery, the cost of recycled water is about 50-60% of the current cost. Any increases in the cost of energy will increase the cost of BWSSB water. Hence, we should encourage development of many self sufficient communities. BWSSB, BDA, Corporation, Karnataka State Small Scale Industries Development Corporation etc. should participate in these activities. Subsidised water supply to consumers should be avoided.

A third alternative is to form a cooperative of interested parties (like industries, commerce and organizations) or a joint sector company with BWSSB to recycle water from Bellandur tank. More than 40 million gallons of water is reaching this tank every day. If a part of this water is completely treated and pumped to the neighbouring industrial areas like whitefield, etc., this can become a major, economically viable, alternate water supply system. Details of pumping, piping methods

---

*Note :* \* One of the earliest integrated treatment plant producing biogas is in existeaco in the 'K and C' Valley-near Bangalore air port.

can be worked out based on constraints of bulk water distribution, use of existing pipe lines, introduction of a separate drinking water system etc. Similarly another system on vrishabhavati valley on Mysore road can be set up to treat and supply water to the neighbouring industries.

Figure 1, 2 and 3 give schematic descriptions of urban water systems in general.

### **8. Organizational Structure :**

In order to bring in a new culture in water supply, certain organizational changes are desirable. These are mentioned briefly below :

- (i) The problem of distribution becomes simpler if the partitioning of the city into many divisions by the City Corporation, BWSSB, KEB, etc. can be done uniformly as far as possible. If the boundaries of divisions are the same for all public utilities or integral multiples for all utilities, then cooperation, analysis and problem solving become easier.
- (ii) There is greater need for liaison and coordination amongst many agencies involved in the public service work. This activity is useful both for planning and operation. So when a new area is planned, we should resort to an integrated plan for that area based on the growth of population and on the land use identified for that area. The planning process of a new satellite of a city should involve all agencies like KEB, BWSSB, BDA, Town Planning Dept., Urban Arts Commission, BTS/KSRTC, KSSIDC, Forest Dept., State Pollution Control Board, PWD, Secretariat, Defence, etc. Successful operation also involves co-ordination amongst public utilities. Many times, consumers have to run around amongst various agencies to get their complaints redressed. Even within an organization like KEB or BWSSB, sometimes one has to see many persons to get solutions or remedies for a problem. Many organizations are trying to solve this aspect of consumer grievances. But it is becoming necessary to have areawise co-ordination committees to solve inter organization problems.
- (iii) Many cities abroad have both public and private water supply companies competing with each other. This increases service conditions and improves supply. It was also found that rates charged by both are nearly the same.

Hence, we should consider the possibility of setting up either a co-operative to run water supply system for a community or a joint sector company—with BWSSB as one partner—to undertake water supply and / or distribution activities. Industrial area development boards, small scale industries development corporations, industrial associations (like KASSIA or Greater Mysore Chamber of Industries etc.) are ideally suited to set up such ventures. These ventures will have many advantages like (a) they are run by people in need and people using the facility—so localised feedback systems will help in stabilising the organization ; (b) finance can be generated from the public so this will not be another burden on the government ; (c) responsibilities of routine work will be minimal to the government, so the govern-

ment can concentrate on important developmental works ; and (d) since many such ventures use waste waters, the environment will be cleaner and there will be certain amount of self legislation on this aspect in the communities governed by these ventures.

Because of these advantages, the government should encourage the setting up of co-operatives and joint ventures with private participation.

- (iv) Town Planning approach should inculcate the philosophy of self contained sectors. A city or extensions to a city should consist of a number of sectors—each sector is self contained regarding its many requirements. Currently, we look at some needs like schools, shopping centres, hotels / restaurants, hospitals / nursing homes, transport depots etc. In addition, a sectoral design should include a plan of self contained water system like a lake. If each sector or a set of 4 or more adjoint sectors can identify a site for a lake to tap rain waters, then this can be used for meeting partly the water requirements of the community in these sectors. Such an integrated plan would also take care of the need for open spaces and gardens. So, an ideal plan for the development of a sector should include a constraint on a near self-sufficiency of water.
- (v) Industries set up waste water treatment plants to fulfil the conditions imposed by the water (prevention and control of pollution) Act. Whenever there is a power/energy cut, these plants are the first ones to be affected ; they are shut down. Also, as they are considered by municipalities, corporations as unwanted babies, not much care is taken in their maintenance and upkeep. Hence, it is necessary to provide encouragements so that waste water treatment plants are successful. Wherever possible, free technical consultancy should be given to them to set up integrated plants producing by products (like biogas for meeting their energy needs) so that the operation of these plants becomes a financial success. Secondly, the energy consumption by these plants should be metered separately and the power/energy cut rates for these plants should be minimum—atleast a differential rate is desirable. Financing Institutions should have priority for lending money for these activities—setting up of waste water treatment plants.
- (vi) Water charges for the domestic consumers in Bangalore city are fairly low. Many people surveyed by us have told us that their water charges have more or less remained constant for the past ten years or more\* (In some cases, it has reduced because of lesser availability of water). The following observations are worth mentioning. “In many households, the water charges are the lowest. The charge is very much lower than the money paid for a visit to a cinema hall. It is quite insignificant compared to the salaries of

---

\*This was checked quickly by an industrialist in his office through a random sample survey—many people pay less than Rs. 10/- per month for their water charges to BWSSB.

people – it is less than 1 per cent of salary of many”. “There is actually no such thing like an economic price for water. Since it is a necessary commodity, many people are prepared to pay or are paying about Re. 1 per bucket of 20 litres. (This works out to Rs. 50 for 1,000 litres as compared to less than a rupee charged now)”. As already seen in the section 2, the percent increases in water charges during the past 50 years are quite lower compared to the percent increases in the prices of commodities. So, the current pricing is so low, that it does not allow for large scale modernizations, does not generate capital to get additional water supplies and does not allow for improvements in the distribution system or pump houses.

Because of these two factors namely (i) low water charges, and (ii) willingness of people to pay more for water,—it is desirable to cost the water supply assuming current rates for the accrued capital works, reasonable interest rates and a meaningful rate of return for the capital put in by BWSSB.

Similarly, graded water charges need a relook. This affects large consumers very badly. A large consumer may not waste or misuse water. In the case of industries, grading of water charges should be done based on water consumption/rupee of production or other similar indices like water consumption/month/rupee of capital etc. Because small scale industries come under the first or second grade they may pay a lower rate. So, a clever industry can divide itself into many smaller ones to take benefit of this charging by BWSSB and pay less for its water consumption. This higher tariff is particularly true for large institutions like Indian Institute of Science. If a major colony draws water and distributes it amongst its individual households, then it has to pay initially for the pipe lines to be laid for the distribution system and also pay a higher charge for the water. This is doubly punishing for such large institutions and colonies.

(vii) In order to take up major works for water supply, we need finance. Public, I am sure, will be willing to participate in any bonds issued by BWSSB if they perceive and understand that these contributions will get them better water supply in addition to earning reasonable financial returns for the money invested. To generate about 10 crores of rupees, the 1.6 lakh consumers need to invest about rupees 625 per head only. Larger capital generation is also possible.

(viii) Since the administrative burden on a single organisation becomes quite high if it takes up water storage and tapping, transmission, temporary storage, distribution, purification, pumping, sewage treatment, customer satisfaction, operation and monitoring and other activities, it is desirable to split up some of these. From this point of view—distribution—mostly customer oriented—needs to be separated. It can also be entrusted to co-operatives like Ex-service men's associations in different areas on a contract basis for operational purposes. This is similar to franchising—while BWSSB may retain overall control, local operations are handled by the cooperatives.

(ix) Water distribution to households is controlled by valves operated by valvemen. In many localities, people (consumers) are controlled by these valvemen. We can even say that they are under the mercy of these valvemen. In these days of low cost high technologies, BWSSB should seriously consider installation of automated openings and closings of valves by means of an electrical system with a timer, automated control of valve positions by the same electrical system, and monitoring of flows in individual pipes at the service stations. Such a culture exists in the electricity boards. Since, instrumentation has received a low priority, in our scheme of things, we are still controlling local distribution through such manual means leading to problems of human inefficiency, inaccuracy and corruption. Introduction of good instrumentation control and monitoring systems as well as the introduction of a central dispatch centre with automatic flow of information from all service stations have become possible, feasible and inexpensive with the advent of computer based technologies. BWSSB has some previous experience because of the installation of control systems in their transmission main. Hence it is desirable that they take up these modernization schemes. Some of the advantages of this are :

- (a) Elimination of human element – a valveman who decides whether a street gets water or not and if so, how much. This creates competition leading to undesirable activities.
- (b) Better control of water flows in the distribution lines so that it is possible to optimize equitable distribution of water amongst many distribution lines.
- (c) Better and accurate monitoring of water flows, water distribution and redressal of consumer grievances.
- (d) Better control of leakage of water. It is estimated by some experts that upto 10 per cent of water is leaked out and so it is desirable to locate the points of leakages in the distribution pipeline network and take immediate remedial actions. Currently, detection of leaks in pipelines takes longer time delays. But an instrumentation and control system at a service station can quickly check for total flows at every junction and detect quickly the existence of major and minor leaks. Once these are detected, then the workmen can be sent to the spot for immediate repairs.
- (e) It is possible to maintain satisfactory water supplies to all consumers – both quantity of water and pressure of water to the satisfaction of a consumer.
- (f) An important advantage will be the creation of a good, reliable and upto date data base. This will be very useful to BWSSB and the State Government in the following activities: Consumption analysis; performance monitoring; design of improvements to the distribution network like adding a new line, augmenting a pipeline and the need for introduction or augmentation of capacity of pump houses; understanding the working of service stations; information

transfer to and amongst service stations; estimation of reliability and operational figures for several components like pumps, motors, valves, pipelines etc. and consequent selection of proper components, proper technologies and manufacturers; operations planning for each week, month and year and the consequent water need supply balance for a year; projection of water demands of various service stations and various sectors for the next 10 or 20 years; planning and design of augmented water supply and distribution systems to meet the future demands; determination of locations, types, sizes and technologies of temporary storage reservoirs; etc.

- (g) With the availability of a computer in the dispatch centre and availability of current data, optimal operation is possible. It has been shown in many urban water supply systems that the online optimization of pumping parameters – determination of heads and flows at various pump houses for a given set of demands – has reduced the cost of operation considerably leading to a rate of return of 1–2 years for investments in instrumentation and control systems.

Similarly, cost reductions are possible during the planning stage also. At present, planning activities are limited to considering a few options; but CAD (computer aided design) will be able to consider a large number of options. So, even a simple problem like augmenting a distribution line at a place can be analysed locally and globally considering many values for parameters like pipe diameter. Based on this, one can come up with a design with the lowest cost. So, if CAD is used in the design of our urban water supply system, we can come up with good designs with minimum costs. Again these cost reductions have made the return on investments on the CAD and instrumentation systems to be very attractive in addition to improving customer satisfaction.

The availability of inexpensive, good and networkable Indian computer based systems should make it easy to set up computerised dispatch centres and instrumentation and control systems.

Modernization will help in improving the management activities also. Figures 4 and 5 give the structure and functions of a dispatch centre. It can be implemented in stages also.

- (x) As far as Bangalore Water Supply is concerned, there is a very close linkage between the problems of water and energy. Poor availability of water – both head and quantity – has resulted in the people going in for pumps to pump water to overhead tanks from their sumps. The energy consumed by many consumers – both domestic and non-domestic, for this activity is nearly the same as the energy consumed by BWSSB. But to quote Mr. S.G. Ramachandra, an energy expert at Bangalore, the energy consumed for water pumping by consumers is nearly twice the energy consumed by BWSSB. This reveals the need for an integrated plan for energy and water.

- (xi) Categorisation of consumers also needs a relook. Instead of putting all other consumers into the nondomestic category, it is desirable to use standard categorisations used by other utilities like electricity boards. This is also desirable because of the uneven effects of graded tariffs for water. Further, statistical analysis becomes meaningful when applied to a group consisting of similar users. Today, we are not able to draw any conclusions from the use of water by nondomestic consumers.

### **9. Establishment of a monitoring group**

Since many of these suggestions cannot be implemented by BWSSB on its own, and as many other agencies like BDA, corporation, KEB, BMRDA, Directorate of town planning, Housing and Urban development ministry etc. are also involved, implementation has to be looked upon as a total activity by the state government and a set of policies are to be evolved for various organizations. Based on these, the organizations can implement the decisions in consonance (and not in opposition). The policies should put a stop to agencies working on opposite directions. In order to coordinate these, a permanent monitoring group with representatives from various agencies and experts needs to be set up. The functions of this group are (a) monitor the progress of various agencies and solve inter agency problems; (b) avoid policy implementations in opposite directions; (c) plan for the balanced growth of the city for the future, priority areas of development and identify penalties for unbalanced growth in certain sectors; (d) develop policies for balanced growth based on past experience and future growths so that the State Government can take suitable follow up actions on these. This will provide for an integrated development of a city on a sectoral basis. The monitoring group can analyse futuristic growths and suggest alternate locations or cities for a type of growth. This can be explained through an example.

The State Government normally receives requests whenever a large institution or organization or industry is to come up in Bangalore City. This is because of the large area/power/water requirements of the institution/industry. Lack of scientific data and co-ordination makes the decision making process arbitrary and sequential. The monitoring group can look at the requests and identify areas or sectors for total development, with the industries/organizations also participating in this development process both financially and physically. In case, the monitoring group finds the setting up of such an industry to be costly to the society, it can suggest alternate cities. One example of a integrated effort similar to this approach is the electronics city, being developed by KEONICS (Karnataka State Electronics Development Corporation).

Secondly, the group can look at factors that attract people (and industrialists) to a big city like Bangalore (these are well known according to many); and work out developmental costs for developing these factors in other cities in the state. If unit costs are worked out based on these, then one can compare the

advantages between various locations and cities. So instead of localising the problem to Bangalore City, it can identify other places as well and come up with an optimal solution.

That is, the group may find locating an industry in another city (plus development of many additional attractive factors) cheaper to locating it at Bangalore. This stems from the fact that even today, unit costs of water, site, energy, transport, etc. at Bangalore are quite high compared to unit costs of these in other cities. This can lead to defining a combined unit cost for all services. Let us calculate the integrated unit cost of additions to Bangalore City. Now we have to attract industries/institutions to other cities. Then, it is desirable (or essential) to develop infrastructures like schools, colleges, hospitals, markets, communications, transport-air, rail and road to the neighbouring bigger cities, etc. in these other cities. These capital costs are included and a total unit cost is developed including cost of development. So, if we consider a set of unit costs for several cities and Bangalore, we may arrive at some or many locations and cities whose unit costs are minimal and this can also result in a scientific development of new cities. (The whole premise is based on the facts : (a) unit costs of Bangalore City are higher – This is true and can be established. (b) Every city has an optimal growth rate – for the initial growth rates, the unit costs are high ; with increasing growth, the unit cost values come down reaching an optimum value ; for higher values of growths, the unit costs increase again. This suggests that there is an optimum carrying capacity for a city.)

One can also include other related costs for the movement of people to cities like uneconomical maintenance costs for rural areas and small cities with depleted populations – like the cost of transport, rural electrification, piped water supply, technical education, health and medicare etc. as well as social costs due to movements and deterioration of quality of life etc. This will give us a total systems view on urban development.

The above establishes clearly the need for setting up a monitoring group for urbanization which looks at not only the balanced growth and development of facilities in a city, but also on the balanced growth of the cities and rural areas leading to minimal migration – both number of migrants and distance of migration.

Since, the work of the monitoring group might encompass aspects of relative-ness of development of cities and aspects of infrastructure development, as well as aspects of policies, planning co-ordination and monitoring of operation, the structure of this monitoring group should be a hierarchical one. (Fig. 16) That means, the monitoring group consists of sub groups ; - the subgroups can be structured on the basis of functions like policies, planning, operation. Since a large number of data bank (creation, storage and operation) activities, studies and analysis are required, the main group and subgroups can have a number of study groups. The main group identifies problems ; similarly, the sub groups may also identify a number of problems related to their functions. These are passed on to the study

groups consisting of specialists who can analyse these problems and come up with many alternative solutions. These solutions form the basis for discussions by the main and subgroups to arrive at answers and decisions on the posed problems. The study groups will be dynamic – not permanent, – but the other groups will be permanent.

The one pertinent question that comes to our mind is why do we need these monitoring groups – can we not use existing structures of the Government to handle these problems. The answer to this can be got by listing out some of the needs and advantages of a monitoring group :

- (a) Since many problems are of inter-disciplinary and inter-departmental in nature, a centralised group can co-ordinate and direct various activities.
- (b) Since infrastructure development involves public, – households, industries etc.– a combined group will be able to perceive the problems of the public and the service organizations in a better manner. Various segments of the public will get a feeling of involvement.
- (c) Involvement of experts in study groups can bring out indepth analysis of many problems. This provides for a structured involvement for experts. At present, experts are not involved in the improvement studies in a permanent manner. They can also have a second or third look on a problem.
- (d) The groups may not work under pressure ; so they can come up with answers for tomorrow after detailed considerations and discussions. There is no day to day fire fighting activities for this group unlike in government departments.
- (e) There is still a large amount of isolation amongst various agencies, institutions, experts, consultants, and consumers in our country (creating a number of ivory towers). This monitoring group will provide an opportunity for them to interact with each other.
- (f) Innovative ideas from individuals will be considered and may be implemented.

Certain other aspects, which need attention so that the activities of a monitoring group will be successful, are :

1. The monitoring group should have certain powers. A purely consultative committee (like the railway's consultative or users' committees) may not be able to solve the problems facing the city.
2. The groups' decisions should be implemented – either through government orders or legislative means.
3. The study groups' activities should be time bound. Problems of a study group can be given to experts as projects.
4. A statutory status is desirable.

An example similar to this tried by the state government is the economic and planning council for Karnataka. Since urban growth and urban activities involve many functions and factors (not only water), it is desirable to have a monitoring group as suggested in this section.

**10. Summary of conclusions and suggestions :**

Based on the analysis of data and our surveys, the following points emerge for serious consideration and implementation.

- (i) For the first time, an attempt for a detailed data organization and data base creation has been made. A map of Bangalore City showing BWSSB divisions, subdivisions and service stations has been prepared. Another map of BWSSB, BDA and projected BMRDA areas (by 2000 A. D ) was superposed on a large map of partial Bangalore district, with the idea of identifying locations for rain water storage. It is desirable that this activity should be continued and the data base put in a computer for easy access to BWSSB and government officers.
- (ii) The analysis of domestic water consumption reveals that there is a large disparity on water consumption in different localities (Figs. 9, 11)\*. Sixteen out of a total of twenty eight service stations have a per capita consumption less than the average (Fig. 12). Five service stations have a per capita consumption which is greater than two times the average. The lowest per capita consumption is 20.04 litres/day and the highest is 119.5 litres/day. This shows a ratio of nearly 1:6.  

This means that a relook at the distribution structure, piping network, and pumps becomes essential.
- (iii) The domestic water consumption analysis also shows that 14.83% of the population consumes 7.45% of the total domestic water and similarly on the higher side, 11.29% of the population guzzles 24.41% of the total domestic water. This also is reinforcing the belief that a relook and re-structuring of the distribution system is needed.
- (iv) Water consumptions in public taps as provided in the statistics of BWSSB and as calculated based on our surveys seem to vary considerably. There is no statistics available on the number of people depending on one public tap. Our survey on public taps contains the following information. Per capita water consumption varies from 10.75 litres/day to 76.8 litres/day—a variation of seven times ; maximum possible consumptions per capita also varies from 11 to 111 litres/day—ten times. Number of persons/tap varies from a minimum of 40 to a maximum of 428—again ten times ; quantity of water/day varies from a minimum of 430 litres to a maximum of 13975 litres/day. Even in a public tap itself, there is a disparity in per capita water consumption—one or two families guzzling a large percent of water.

---

\* Domestic consumption constitutes 54.8% of the total water consumption; public fountains 23.3% ; non domestic 12.9% (This is for the year 1983). Hence the domestic sector was analysed further.

- (v) There is a monthly variation in the water consumption in domestic sector in many service stations (Fig. 13). This fact can be used in planning monthly or weekly supply – demand balancing studies.

The existence of monthly variations was observed through the existence of the months with negative growths in water consumptions in many service stations.

- (vi) It is desirable to have a uniform coordinated approach amongst various agencies in partitioning the city into many zones – divisions, subdivisions etc. If they use an integral number of divisions of the corporation as their zones, it is easy to identify them and compare inter service variations. This will also help in approaching towards an integrated planning of the sectors or zones.
- (vii) Surveys of industrial water use shows that a large part of water in many industries goes towards washing and cleaning activities. These uses do not require high quality water. It is desirable to go in dual water systems; many industries already are moving towards this by recycling their waste waters.
- (viii) Washing of vehicles consumes a large quantity of water. 8.75 million litres/day is estimated towards this. It is desirable to construct platforms on existing lakes with a set of jets so that vehicles can be taken to these lakes for washing. KSRTC should provide a lead for this by building washing platforms in some of the lakes still existing in the city or in the Belandur tank. Others may be persuaded to follow this practice.
- (ix) Study of a few slums tells us that per capita water consumption varies from 16 litres/day to 23 litres/day. Population depending on a water source (like well or public tap) is high when compared to the population using public taps in developed areas.
- (x) The water distribution system being a major activity completely intertwined with the public, it is desirable to restructure this function of BWSSB. One of the important needs is modernisation. Instrumented control systems should be installed at all service stations, subdivisions, divisions and the main office. A centralised water supply control centre should be developed. The dependence on human elements on valve opening, closings and adjustments should be minimized and if possible, avoided. Low cost technologies for instrumentation and control makes this possible. Engineers and operators should be trained for operations of these systems. Leak detector systems should also be installed or atleast leak monitoring software at a service station level can be put to use so that leakages can be reduced.
- (xi) Approach to urban water development should have as a goal creation of self sufficient communities. We cannot depend on rivers as our **only** water source (for Bangalore city). There are competing needs for it –

irrigation, water needs of other cities etc. Industries, establishments, institutions should be exhorted to conserve water. A water conservation manual should be prepared for each sector publicised.

- (xii) Water conservation will remain a pleasant dream, if water charges are low. The water supply charges of BWSSB have not increased at the same rate as other items. The increase in water charges in the past 50 years is only four fold; the charges were around 12 paise/kilo litre in 1934 and are graded varying from 0 (free) to 50 paise to more (now). During the recent years, the changes in water tariff do not reflect the changes in price index. At the lower end of domestic consumption, the tariff has increased from 25 paise in 1969 to 40 paise in 1981 (not even two times). Many families pay less than Rs. 10/- per month. This is less than 1% of their monthly salary. (less than their expenses for a visit to a cinema house)

So in order to improve distribution system as well as help in the introduction of new and additional sources, we need to generate funds. This coupled with the need for water conservation suggests that the tariff should be reasonable and not so low as the present one. The tariff should be calculated based on replacement costs and current costs of water supply systems instead of the existing approach based on depreciation.

- (xiii) Rain water can meet upto 30% of our current water demand. But there has been a steady destruction of this form of water supply. There were about 140 lakes in 1931 and 16 today many of the existing lakes have shrunk in volume and area considerably. This has led to many problems - (a) look for new sources to meet our demands; (b) disposal of rain water thereby overloading the sewerage lines; (c) flooding of streets during heavy rains; (d) polluted storm water drains; (e) lesser recharge into earth there by reducing ground water potential in the city area; (f) reduction of open spaces, recreation areas etc.

Two reasons for this closure of lakes are (a) mosquito menace; (b) pollution of a lake (in addition to the commercial value of the land to BDA). Proper maintenance can reduce these problems. Hence, the corporation or BWSSB should establish a tank maintenance division. This division should keep water drains clean and also keep the lake waters clean thereby reducing pollution and mosquitoes generation. Public also should be involved in this. (examples are the effort of Rotary clubs in cleaning the Ulsoor lake; students of Mysore University in cleaning the Kukkerahalli Kere in Mysore city). Since, pollution control is essential (as per the act also), any way BWSSB has to treat these polluted waters (the rain waters instead of reaching the lakes will reach the sewerage system and will have to be treated there). Similarly, dirty and unclean storm water drains create unhygienic conditions leading to health hazards.

So these multi fold advantages tell us that we should accept rain water as an important component of our city's water supply system.

- (xiv) We can augment existing lakes, clean up and strengthen the drains network and also identify many locations for lakes on the outer annular ring of BDA/BMRDA area. A large number sites are possible and feasible as locations for lakes. From the economic cost point of view also, it can be shown that the cost of water from a lake put up in a developed area including the annual costs due to the land also will be less than the cost of cauvery water.

As a first step, the government should put a ban on the conversion of tanks, lakes and ponds into private/public sites for buildings by various agencies including BDA, Corporation, BMRDA etc.

- (xv) The problem of protection of the tank/lake system to store rain waters – a good tradition we have inherited from our forefathers – needs to be handled in the same manner as we attack today the problem of deforestation through massive afforestation programmes. The zeal and enthusiasm generated for the social forestry program deserve emulation for preservation, cleaning and protection of our lakes.
- (xvi) Regeneration of lakes will improve our micro environment, bring back with glory the name of garden city to Bangalore and also compulsorily provide open spaces – lung spaces – in a growing city.
- (xvii) Capital costs of these complete set of lakes and tanks will be very much less than the capital costs of alternate river based water supply systems. To compare, the cost of construction of tanks, assuming removal of total volume of soils, will be around Rs. 20 crores, whereas the cost of the transmission system of Cauvery water alone will be around Rs. 70 crores. In addition, tank construction and maintenance will provide employment.
- (xviii) Even a big city like Bombay gets its water supply from lakes. Madras city also draws its water from lakes.
- (xix) Industries, Industrial Estates and Institutions with large areas like HAL, BEL, ITI, IISc, IIM, Peenya Industrial Estate and Defence Organizations should take up the leadership in the rain water harvesting activities. Many of them can 'build' a minilake or minipond and bring their water drain network to this mini lake. In this manner, Bangalore city can become a model and a leader in setting up self sufficient communities (if not totally self sufficient in water, at least partially). Many such areas under the control of these industries and institutions are clean and it is possible to maintain a low cost, localised water supply and distribution system.

- (xx) Electronic engineers design their systems using a concept called negative feed back so that the systems are very stable. This concept is catching up in the design of societal and economic systems also. So it is essential to use this idea on water supply – demand system. We have to minimize the input (supply) of additional water by recycling (reusing) the water in the system. Since the entire water supplied to the city is not absorbed, waste waters are produced. It is estimated that they constitute about 70-80% of the water supplied. This is a good water source to meet our requirements. Since it has to be treated as per the act, it can be reused for industrial, washing and cooling purposes.\*
- (xxi) There are two ways of using treated waters. One way is for every large organization to treat its inhouse water and use it internally. This reduces the cost of piping. The second method is a centralised treatment system by BWSSB as is being done now. This needs a large sewerage piping network carrying the waste waters to the treatment plants. It is worthwhile investigating the possibilities of setting up many localised treatment plants so that costs of piping will be low and water reuse will be easy.
- (xxii) Waste water treatment and reuse systems are also becoming cost effective compared to Cauvery supply.
- (xxiii) An integrated services design for each sector is desirable. Newer identified areas should be designed to have self sufficiency in many services, particularly on water supply and waste water treatment. It will be an innovative and cost effective approach to plan for self sufficient communities.
- (xxiv) Since BWSSB has its hands full, it is desirable to encourage private groups, co-operatives and organizations to take up the experimentation of such decentralised water supply and distribution systems. Since each community will be using water – both rain and waste waters – mainly from its own area and will depend on BWSSB water to a minimum extent only, such experimentations should be encouraged and supported by the government. BWSSB can also float joint sector companies to develop and operate such systems especially in areas like peenya, white-field etc.
- (xxv) The operations of localised systems and a centralised BWSSB based system will lead to the introduction of viable alternatives and healthy competitions. This will reduce the routine work load of BWSSB. It will also mean the availability of private finances for this purpose.

---

\* Discussions with BWSSB officers reveal that there are no takers for the treated water from the Belandur tank. (K and C valley)

- (xxvi) BWSSB should explore the possibilities of getting finance from the consumers for its various schemes ; since the individual contributions will not be high, response will be good.
- (xxvii) Energy and water are interrelated as far as Bangalore city is concerned (fig. 15). Proper, regular and uninterrupted supply of electricity to BWSSB pump houses can lead to supply of water to consumers at a higher pressure. This will result in a reduction in energy consumption at the consumer level—reducing the energy requirements to pump water from the sump to the overhead tank.
- (xxviii) Similarly, pumping water from ground level reservoirs to distribution lines is also affected by the interruptions in power supply. It is desirable to look at the construction of overhead reservoirs. If we calculate the cost of construction of sumps/ground level tanks and overhead tanks by many consumers—small or big—, then the construction of overhead large reservoirs by BWSSB in different localities will be less costly.
- (xxix) Houses can be constructed with the sewerage line connected only to the toilets and the bath rooms can be 'connected' to the rain water drains or to a drainage system for gardens. This will reduce treatment cost and will work very well if coupled with rain water harvesting systems. This approach should be tried in some colonies initially.
- (xxx) Water is only one component of an urban development activity—but an important and essential component. Balanced development of a city needs detailed studies and generation of policies based on them. Incentives by way of societal developments—schools, hospitals, transport, communications, entertainments and recreations in other cities will help in distributing development in the state. Hence it will be advisable to organize BMRDA not on regular office lines, but as a task force handling problems through various study groups. Participation of experts and public will result in greater understanding and co-operation. The study groups can analyse a problem in depth and come up with many alternatives in planning and policies as well as alternative locations and cities for a particular requirement by an organization or industry.\*
- (xxxi) Pooled development of ground water tapping is desirable both from the aspect of distribution and cost economics. In this connection, the idea of Mr. Phelps suggested in 1921 is worth consideration—the use of underground water by drilling a shaft of large diameter in an inclined manner running over a long distance.

---

\* It is also desirable to bring all service utilities under one common umbrella that of BMRDA executive wing so that condinations amongst the various utilities for water, power, transport, communications and services will be easy and smooth. Fig. 17 suggests an organizational structure for this purpose.

So instead of piecemeal development by individuals and the BWSSB, a scientific tapping and use of ground water is necessary. It is necessary to map out ground water potentials at many areas and identify locations for drilling such shafts. The economics of such a scheme—both capital cost and operating cost—will be very promising. This is worthy of analysis and investigations.

- (xxxii) Detailed studies on water charges especially to industries are desirable. The present gradation of charges is based on the total consumption only. In order to rationalise this, we should prepare norms for water usage for every type of industry—that is the quantity of water needed/unit of production. The charges should be based on these norms. The rate for the actual consumption less than the norm should be low and the rates for consumption values greater than the norm should be high and can also be graded. These norms can be developed in consultation with the industrial groups—similar to the manner in which Indian standards specifications are drawn up—and dynamically changed with time. Water requirements for various groups/classes of industries are known and available; hence preparation of norms will not be difficult (or impractical). These norms can also be used by industries to compare their relative performance with that of other industries in their group, as well as identify problems and problem areas.
- (xxxiii) A special monitoring group is needed to monitor water use by water guzzlers. This group can work like a water auditor and suggest water conservation measures to the guzzlers.
- (xxxiv) Since about 40 million gallons of water flows into the Bellandur tank every day, it is desirable to explore ways and means of setting up a co-operative or joint sector to treat and use this water to meet the requirements of bulk consumers.
- (xxxv) Another concept becoming prevalent in urban water supply systems is the use of dual water systems. It is worth while finding out the possibilities of this in some areas of Bangalore where water density is high. One of the extreme solutions of this is to pump treated waters through the existing network and introduce another distribution mechanism for water of high purity—drinking and cooking level. This stems from the fact that more than 80% of water use does not require high purity water—an example of dual system exists in some parts of Calcutta.
- (xxxvi) Whenever extensions to a city are planned, land use plans are prepared delineating areas reserved for various activities like houses, office/commercial buildings, gardens, schools, hospitals, services etc. In future, we should reserve areas for rain water storage (lakes), and sewerage treatment systems also in the land use plans (Similar to percentage reservations for open space, green belt etc.)

- (xxxvii) Study of sewerage systems is directly related to the analysis of water supply systems. Current technologies on integrated waste disposal systems—both solids (garbage) and liquids—deserve attention, so that we can, in future, integrate these different waste disposal systems (under different administrative units like BWSSB, Corporation, BDA, industries etc.). One of the major advantages will be energy generation and manure production from these systems as by products. This makes an integrated waste disposal system to be economically viable.
- (xxxviii) From many of the above suggestions, we can generalise one approach common to many services—approach of conservation of resources but not protection either protection of rights or protection of monopolism. Currently, many services are worried about protecting their monopolistic rights rather than other aspects of public service like customer satisfaction, co-operation, innovations, conservation of resources and improvement of quality of life. The conservation approach would have resulted in the selection of proper alternatives, in the experimentation of innovative and novel technologies, in the introduction of nowaste and 'dry' technologies and in the ushering in of an integrated plan for an urban system. In short, it should convert an urban system from being a parasite on all natural resources to being a co-operative organism—a self contained and self sustained system generating its resources as far as possible from within.
- (xxxix) Let us mention a related aspect also here. Since BWSSB has a large number of ground level reservoirs, occupying large areas, BWSSB should consider setting up parks in these areas similar to the hanging gardens of Bombay. This will also help us in retaining the name of Bangalore as a garden city.

## **11. ACKNOWLEDGEMENTS**

Data collection would not be possible but for the whole-hearted support and cooperation of BWSSB. We got excellent help from various officers of BWSSB starting from Chairman and Chief Engineers to various persons manning the service stations. We collected data not in one instalment, but in several instalments. Each time we visited BWSSB offices, we found the staff in a very helpful mood to assist us in our needs. We are extremely indebted to all the persons – technical, administrative, operational and accounting sections – in BWSSB who assisted us in our work. Data Collection was done by Dr. Sathyanarayana, Mr. A.K. Kattimani, and Mr. S. Ramakrishna, Project Assistants at the Karnataka State Council for Science and Technology. Many discussions with Prof. Vinod Vyasulu, Indian Institute of Management, Bangalore, Prof. Rama Prasad, Indian Institute of Science, Bangalore, Mr. S. Rajagopalan, KSCST and many others led to value additions in this work and our acknowledgements are due to all of them. Financial assistance by KSCST made this work possible. Staff of KSCST – especially Mr. K. A. Srinivasan and Mr. G. Panduranga assisted us at many stages in the course of our work.

Discussions with many persons like Mr. S. M. Agarwal, Mr. S. Lakshman and Mr. V. M. Bhat of Greater Mysore Chamber of Industries sharpened the focus on many aspects of management of our water distribution and supply systems. Many industries like Bangalore dairy, Kissan products, Electroporcelains division of BHEL, Vitaz food products and many other small scale industries provided us facilities to conduct studies and also helped us at various stages. Similarly, a large number of domestic consumers cooperated with us in our surveys. Our thanks are due to all of them.

Mr. R. Doraiswamy readily helped us in costing the water treatment plants required in many case studies. His assistance is also acknowledged.

## APPENDIX-I

**Organization of BWSSB**

The Bangalore Water Supply and Sewerage Board (BWSSB) is formed by an Act of Legislature in 1964. The Board is entrusted with the general duty of providing supply and improving the existing supply of water in the Bangalore Metropolitan Area and of making adequate provision for the sewerage and the disposal of the sewage in the Bangalore Metropolitan Area. The BWSSB comprises mainly of two divisions – North and South, which, in turn, consist of four and three sub-divisions respectively. There are a number of Service Stations in every sub-division, the details of which are given below :

**A. North Division***I. No. 1 Sub-division*

1. Malleswaram
2. Srirampuram
3. Yeshwantpur
4. S. D. Halli

*III. No. 3 Sub-division*

9. Low Level Reservoir
10. Chicklalbagh
11. Bannappa Park I
12. Bannappa Park II

*II. No. 2 Sub-division*

5. High Ground Reservoir I
6. High Ground Reservoir II
7. Kumara Park
8. Gangenahalli

*IV. No. 7 Sub-division*

13. Rajajinagar
14. West of Chord Road
15. Vijaya Nagar
16. Magadi Road

**B. South Division***I. No. 4 Sub-division*

17. Chamarajpet
18. M. N. K. Park
19. Mount Joy
20. V, V. Puram

*II. No. 5 Sub-division*

21. Jayanagar
22. Byrasandra
23. Koramangala
24. Banasankari
25. Sarakki

*III. No. 6 Sub-division*

26. Machalibetta
27. Johnson Market
28. Ulsoor
29. Indiranagar
30. Jeevan Bheemanagar

Thus, there are 16 and 14 Service Stations in North and South Divisions respectively.

## **APPENDIX-II**

### **Some examples of the use of waste waters**

The military engineering services authorities use Ulsoor water in Bangalore for gardening. They are drawing about 1,20,000 litres/day from the lake. Since about 7 million litres/day of waste water enters the lake, it is possible to use the water after installation of a sewerage reclamation plant. The cost of such a plant is estimated to be around fifty paise per 1000 litres of water (compared Rs. to 3-4 of municipal water).

National Dairy Research Institute uses waste waters for irrigation purposes—about 2.5 million gallons/day is the requirement for cultivation of fodder in 62 hectares of land belonging to the Institute. Southern Organochemicals Limited, Bangalore is planning to reuse a major part of their waste water for cooling and refrigeration purposes.

HMT, Tumkur has been using treated waste water and it has estimated a net savings of Rs. 2.40,000/year in the cost of water.

Bethlehem Steel Comprny, Baltimore, Maryland has for many years been treating 150 million gallons of water everyday and using the water as cooling water. The cost of water is very low and the city also receives a revenue on the sale of the effluent. The Texaco Inc., Oil refinery at Amarillo, Texas uses over 1.5 million gallons/day of treated municipal sewerage water for cooling and boiler make up. The water charges are about 60% of the charges for municipal water. Many other companies and power plants have been reusing treated water for cooling and boiler feed purposes for more than 40 years.

In the USSR, the chemical industries have introduced low water consumption and effluent free technologies. About 22 major industrial non-ferrous industries are operating without discharging any effluents. There are more than 1200 major industrial projects built in USSR with low waste or waste free technologies.

### **Reuse of waste water in Bombay**

Several multistoreyed buildings with sewerage flows of the order of 16000-30000 gallons/day are reusing their waste water after treatment as make up water for airconditioning. In 1970, a plant costing Rs. 50 lakhs was put up by a chemical industry to treat 4.5 million litres of sewerage water/day for use in its cooling and heat exchanger systems. The cost of treated water after softening was Rs. 3 per 1000 litres. This includes cost on capital expenses. The cost of municipal water to the factory is Rs. 6 per 1000 litres. This plant is operating successfully since 1970.

### **Dual Water Systems**

This means that two water supplies are given to a city one for domestic use and the treated waste water for use in industries, agriculture, recreation, parks, cooling, fire fighting, cleaning, golf courses etc. The treated waste water can also be used in public buildings for toilets. A dual water system is in use in Arasikere town. The rain water and municipal run off of the town enters the Thimmappanayaka kere and it is supplied after treatment to the town for secondary purposes. House

connections are not given to this source of water supply. Such systems are used in many countries—Bahamas Islands, Hong Kong Island, San Diego county, San Francisco (Golden gate park), Los Vegas, Pamona (California) etc.

### APPENDIX III

#### Case Study : Peenya Industrial Area

As an example of self-sufficient water supply generation, let us consider Peenya Industrial Area—one of the largest in India and Asia. Our objective here is to see whether this area can generate water supply in its own area so as to meet its requirements of water leading to a self-sufficient and self-contained system.

The Peenya Industrial Area has the following essential characteristics ;

	Stage I	Stage II	Stage III	Area	Total
Number of Units	398	414	95	605	1512
Employment—Total	8757	9156	2100	12705	32718
Investment—(Total) (lacs of rupees)	3760	4303	1055	6032	15120
Production (Sales) (lacs of rupees)	6493	6789	15£7	9420	24259
Value added (lacs of rupees)	1948	2007	467	2826	7278
Area (acres)	125	141	60	1400	1726

The total area of Peenya is estimated to be 25 sq. kms. The industrial area is about 7 sq. kms. There are two ways by which the needs of the area can be met : (i) rain water harvesting, (ii) recycling of waste waters.

If we assume the expected consumption level to be 1 million litres/day, the available waste water will be 0.8 mld. This can be treated, and reused for industrial and cleaning needs of the area. Let us look at both alternatives.

**(I) Rain Water Harvesting :** If we tap the rain water in Peenya area, we will be able to get about 20 mld. of water. If a lake is constructed with an average depth of 3 metres, then the area of the lake will be 2.5 sq. kms. It is possible to think of two or three lakes also instead of one. This area will be about 10% of Peenya.

Instead, we want to meet the water needs of Peenya only. Then the area of a lake will be 0.125 sq. kms. (12.5 ha) only. This is 0.5% of the area of Peenya and can easily be identified.

Thirdly, we may also consider the case of using re-cycled water for meeting 60% of their requirements and tapping rain water to meet the remaining 40%. In this case, the area required will be 5 ha. only. This is a very small percentage of the area of Peenya (0.20%). There is already a lake existing in that area according to the information with BWSSB.

As it is, rain water drains are available in various streets. The steps needed to develop a lake are—

- (i) Identify a site of about 3–5 ha. suitable for a reservoir ;
- (ii) Augment drains and develop inlets (open or closed type) to the reservoir.
- (iii) Construction work—mainly digging work—can be taken up under many development schemes of the government like NREP.

The cost of these constructions will not be much if construction is limited to mainly mud based work only.

**(II) Waste Water Treatment and Re-cycling :** The second alternative is to get a major part of the industrial water needs by treatment and reuse of waste water. So it is possible to get 0.8 mld. from waste water. The cost of a water treatment plant to treat 1 mld. will be around Rs. 8 lakhs. The total cost including piping will be around Rs. 10 lakhs. This investment will be less than 0.1% of the total investment in Peenya industrial area. (compare total investment of Peenya, 15120 lakhs with this investment of 10 lakhs). This amount should be obtained as a subsidy from BWSSB or government. Since treatment is a mandatory activity of BWSSB, it is logical that the cost of treatment plant will have to be borne by BWSSB. Also, it will be a good policy to encourage self-sufficient communities to be developed in Bangalore City—weaning people away from their total dependence on Cauvery and Arkavathy rivers. So the government should also encourage and help this as a model project. Funds are available with DNES (Department of Non-conventional Energy Sources), Government of India, if we put up a treatment plant with recovery of Methane Gas which can be used as an energy sources.

Even if we do not get funds for the project of treatment, the cost of this capital will work out to about 30 paise per 1000 litres only. The running cost will be around Rs. 2 per 1000 litres. Hence, the total cost will be about Rs. 2.30/kilolitre.

The current rate of water cost for industries varies from Rs. 1.5 to Rs. 4 the average for medium industries being around Rs. 2/kilolitre. If the cost due to capitalization is taken out of consideration, then the cost of recycled water compares favourably with the cost of BWSSB water.

The estimated cost of Cauvery water for BWSSB is around Rs. 3.75/kilolitre. This means that the recycled water is cheaper compared to Cauvery water.

Further, as 50% of cost of BWSSB water goes to meet the energy charges for pumping, any increases in the energy cost by KEB in the near future will increase the cost of water supply by BWSSB. Since the chances of increases in energy prices are high, the cost of recycled water in Peenya will become economical compared to Cauvery water by the time the plant is commissioned and the cost differential between Cauvery water and recycled water will be increasing with years because of this aspect.

Having established the economics of water supply from recycling, let us see how this can be implemented. There are three ways by which the project can be taken up ; (i) as a private enterprise ; (ii) as a co-operative ; (iii) as a joint venture of BWSSB, KSSIDC and some industries.

It has been shown that in many countries, charges by private water companies are similar to charges by government-owned companies and services improve considerably due to competition between these two groups. Because private companies are allowed to use waste waters, water demand on rivers will also come down leading to water conservation.

It is desirable that the State Government should encourage a model co-operative to be set up in Peenya to show the feasibility—economic, technical and social—of running self-sufficient communities.

It is not finance that is a major constraint in setting up co-operatives to collect and treat waste waters and supply it in bulk to industries, but the aspect of organisation—technical and day-to-day maintenance and operation aspects. This aspect needs a careful attention. A well thought-out organisational structure will lead to the success of these co-operatives.

#### APPENDIX-IV : Some Industrial Uses :

##### Kissan Products Limited :

This industry manufactures products based on fruits and vegetables like juices, jams, sauce, pulps and canned vegetables—an industry dependent on water. Their main source of water is from the borewells. This industry is a good example of a self sufficient unit as it is meeting most of its water needs from internal sources. The water requirements depend heavily on seasons.

Water consumption is as a given below :

1. Boiler make up	132,000 litres / day
2. Juice line	12,000 litres / day
washing	10,000 litres / day
3. Juice extraction	20,000 litres / day
washing	4,000 litres / day
4. Jam line	8,000 litres / day
washing	15,000 litres / day
5. Ketchup / sauce	4,000 litres / day
washing and cleaning	20,000 litres / day
6. Human consumption	2,000 litres / day
Bathroom, toilets etc.	38,000 litres / day
	<hr/>
Total	.... 265,000 litres / day
Washing requirements	49,000 litres / day

The factory uses about 54,000 litres / day for its gardening activities.

**BHEL Electro Porcelains Division :**

This industry produces insulators. It was started in 1932. The main source of water for this industry is BWSSB. It also has borewells and one open well to supplement the water supply. Water is used in different processes, toilets, canteen and other purposes. The detailed water requirements are as follows :

Clay washing	30,000 litres / day
Grinding of raw materials (slurry formation)	80,000 litres / day
Blungers	7,500 litres / day
Washing filter clothes	12,500 litres / day
Glazing, testing	1,50,000 litres / day
Boiler	50,000 litres / day
Canteen	35,000 litres / day
Foundry	40,000 litres / day
Others	11,000 litres / day
<b>Total</b>	<b>4.16 lakh litres / day</b>

The above also shows the possibility of using treated water waste for washing and other purposes.

**TABLE-1**  
**Water Supply and Demand Projections**

Year	Gross Demand* (MLD)	Gross Supply (MLD)	Shortage (MLD)
1971	162.75*	162.75	—
1980	300.0*	300.0	—
1982	820.00	435.0	385.0
1985	1017.65	435.0	582.65
1990	1354.12	705.0	649.12
1995	1691.18	705.0	986.18
2000	2025.30	705.0	1320.3
2001	2080.50	705.0	1375.59

The large difference in the gross demand between 1980 and 1985 is due to the fact that the demands for 1961 and 1980 are based on the actuals and the demands for 1982 onwards are based on the projections done by BWSSB.

\*The starred figures are actuals, the other gross demands are projections.

NOTE :—MLD=Millon litres/day.

**TABLE-2**  
**Water Availability per Capita**

Year	Gallons/Day/Person
1910	10.6
1921	15.0
1933	18.0
1951	10.7
1958	13.0
1967	20.0
1982	16.0

**TABLE-3**  
**Water Inflow into Bangalore (MGD)**

Year	CRS	SD Halli	Cauvery	Total
1921	—	—	—	1.5
1951	—	—	—	11.0
1980	28.82	1.65	28.61	59.08
1981	28.50	1.03	28.60	58.13
1982	31.17	1.91	32.6	65.68
1983	32.77	2.00	40.36	75.13

MGD.—Million gallons per day

**TABLE-4**  
**Proposed Water Supply from Cauvery**

Cauvery Scheme	Year of commissioning	Expected Water Demand in M. L. D.	Total Supply M. L. D.	Shortage
I Stage	January 1974	242.92	228.50	14.42
II Stage	December 1982	810.75	435.00	375.75
III Stage	1987	921.00	705.00	216.03
IV Stage	1991	1041.62	840.00	201.62

**TABLE-5**  
**Some Salient Details of Water Supply to Bangalore City**

---

Total number of ground level reservoirs	....	17+9*
Capacity of storage in M. G.	...	55.7+44*
Number of overhead tanks (upto 1980)	....	24-28
Capacity in M. G.	....	4.5-5.3
Total length of pipe line	....	1858.80 Km.
Pumping capacity (Transmission)	....	32015 hp
Energy (Transmission)	....	192 m. units
Pumping capacity (Distribution)	....	3927 hp
Energy (Distribution)	....	16 m. units
Revenue receipts (83-84) from water supply	....	Rs. 1812 lakhs
Total revenue receipts (83-84)	....	Rs. 2123 lakhs
Total expenditure (83-84)	....	Rs. 2517 lakhs

---

\*Under Cauvery II stage

**TABLE-6**  
**Consumption of Water in each sub-division (1981)**

Sub- Divn. No.	Consumption (mld)			Industries	Lorry Loads	Rail- ways
	Domestic	Non- domestic	Public fountains			
1	17.813	5.619	10.0	6.84	0.114	2.52
2	10.797	3.07		—		—
3	11.144	7.087	7.5	—	0.023	—
4	18.034	6.5607	16.435	1.727	0.0514	—
5	na	na	na	na	na	—
6	18.476	10.414	16.65	5.55	—	—
7	16.77	2.816*	7.041	—	—	—

**TABLE-7**  
**Consumption in each sub-division in 1982**

Sub- Divn. No.	Consumption (mld)			Industries	Lorry Loads	Rail- ways
	Domestic	Non- domestic	Public fountains			
1	18.53	5.99	9.907	7.75	0.1193	3.004
2	11.56	1.777	—	—		—
3	11.77	7.098	6.761	—	0.0262	—
4	18.598	8.196	16.188	7.042	0.0429	—
5	na	na	na	na	na	—
6	20.99	11.874	16.648	7.904	—	—
7	16.291	2.972*	7.114	—	—	—

\*Non-domestic includes industries also.

**TABLE-8**  
**Consumption in each sub-division in 1983**

Sub-Divn. No.	Consumption (mld)			Industries	Lorry Loads	Railways	Total	Percentage
	Domestic	Non-Domestic	Public fountains					
1	21.48	5.372	10.683	7.51	0.0951	2.9574	48.0975	19.37
2	10.97	2.806	na	—	—	—	13.776	5.55
3	11.466	7.174	7.108	—	0.0252	—	25.7732	10.38
4	32.318	3.966	17.17	2.886	0.0425	—	56.3825	22.72
5	17.967	2.727	3.2104	3.188	—	—	27.0924	10.89
6	25.825	6.782	10.727	5.741	—	—	49.075	19.78
7	16.12	2.936*	9.006	—	—	—	28.062	11.31
<b>Total</b>	<b>136.146</b>	<b>31.763</b>	<b>57.904</b>	<b>19.325</b>	<b>0.1628</b>	<b>2.9574</b>	<b>248.2586</b>	
<b>Percentage consumption</b>	<b>54.80</b>	<b>12.90</b>	<b>23.30</b>	<b>7.76</b>	<b>0.06</b>	<b>1.18</b>	<b>100</b>	

\*Non-domestic includes industries also.



**Domestic Water Consumption in each Service Station**

1983			1984		
Mean	S. D.	S. D. as % of mean	Mean	S. D.	S. D. as % mean
239687	3753	1.5658			
336197	92407	27.486			
68518	3625	5.2906			
94238.1	20401.7	21.65			
77303.6	18832.2	24.36			
106809.3	16896	15.82			
50642.1	23148	45.89			
55461	4939	8.905			
108199	11033	10.197			
90798	2177	2.3976			
89555	8426	9.4087			
264510	89191	33.72			
296044	104314	35.236			
1773638	48270	27.8			
235360	79708	33.8664			
236124.5	12526.9	5.318	257588.5	9356.1	3.63
108256.1	3835.76	3.543	110185.7	4453.2	4.04
147595	7389.5	5.0	131364.7	20824.5	15.85
47033	7741.7	16.46	212722.7	267936.4	125.95
234509.5	8204.6	3.5			
191814.5	10375.8	5.41			
210659	13165.2	6.25			
102895.5	12160.2	11.82			
34866.4	10791.7	14.16			
177518	7658.3	4.31			
100626	3952	3.93			
173152	24513	14.16			
76515	3171.4	4.15			

**TABLE-8 (b)**  
**Seasonal Variations in Water Demand**

Sl.No.	Service Station	1981		1982		1983	
		Average % growth by consumption	No. of negative growths	Average % growth by consumption	No. of negative growths	Average % growth by consumption	No. of negative growths*
1	Malleswaram	.... -1.033	5/11	0.96	5/11	0.463	2/6
2	Srirampuram	.... 0.192	4/11	1.07	2/11	1.831	1/5
3	HGR I	.... -0.873	6/11	0.707	4/11		
4	HGR II	.... -0.869	7/11	-0.439	5/11		
5	Kumara Park	.... -0.344	6/11	0.645	6/11		
6	LLR	.... -0.245	5/9	2.19	5/11	-1.004	3/7
7	Chicklalbagh	.... 0.978	3/8	2.116	5/11	-1.397	3/6
8	Bannappa Park I	.... 0.508	3/8	0.335	3/11	-0.906	4/6
9	Bannappa Park II	.... 4.662	3/8	2.234	5/11	2.004	1/6
10	Basavanagudi	.... -5.263	3/4	0.802	5/11	0.796	1/4
11	Chamarajpet	.... -1.278	2/5	0.600	4/11	13.347	1/4
12	Visveswarapuram	.... -0.866	2/4	2.016	5/11	8.552	1/4
13	Mount Joy	.... 2.933	2/4	2.882	4/11	4.565	0/4
14	Machalibetta	.... 0.178	3/6	0.620	4/11	-0.270	2/4
15	CLR	.... -3.826	4/6	1.478	5/11	-0.681	2/4
16	Ulsoor	.... -5.817	3/6	13.851	3/11	3.893	2/4
17	Indiranagar	.... -3.070	3/6	4.972	6/11	-0.361	2/4
18	J. B. Nagar	.... 2.539	2/6	6.125	5/11	17.375	2/4
19	Rajajinagar	.... 1.017	7/11	0.456	5/11	-0.038	1/4
20	West of Chord Road	.... -1.264	4/11	-0.437	4/11	3.175	1/4
21	Hosahalli	.... 1.529	6/11	-2.209	3/11	0.963	1/4

**TABLE-9**  
**Percent Consumption of Water in each sub-division in 1983**

Sub-Divn. No.	Domestic	Non-Domestic	Public Fountains	Industries	Others
1	44.66	11.17	22.21	15.61	6.35
2	79.63	20.37	...	...	...
3	44.49	27.83	27.58	...	0.10
4	57.32	7.03	30.45	5.12	0.08
5	66.32	10.07	11.85	11.76	...
6	52.62	13.82	21.86	11.70	...
7	57.44	10.46	32.10	...	...

All figures are percentage

**TABLE-10**  
**Number of connections/sub-divisions in 1983**

Sub-Divn. No.	Category				
	Domestic (Number)	Domestic (Percent)	Non-Domestic	Public Fountain	Public (Percent)
1	22602	15.24	1796	576	15.16
2	16550	11.16	1021	576	15.16
3	14420	9.71	2889	553	14.55
4	24088	16.24	1064	638	16.79
5	19712	13.29	2025	180	4.74
6	26519	17.87	1303	797	20.97
7	24459	16.49	1189	480	12.63
Total	148350	100	11287	3800	100

**TABLE-11**  
**Average Consumption/connection in Kl/month in 1983**

Sub-Divn. No.	Category		
	Domestic (Kilo litres/month)	Non-Domestic (Kl/month)	Public Fountain (Kl/month)
1	27.24	77.57	506.38
2	20.36	90.27	...
3	26.48	107.81	385.61
4	40.39	125.30	1370.00
5	26.02	116.16	677.30
6	29.118	159.2	506.61
7	21.79	78.15	578.9
All	27.53	84.42	457.14

TABLE-12  
Percent Rate of increase in consumptions in Service Stations

Service Station	Domestic		Non-Domestic		Public Fountain		Industries	
	81-82	82-83	81-82	82-83	81-82	82-83	81-82	82-83
Malleswaram	.... -1.06	0.88	-4.38	3.91	-11.7	1.45	} 13.32	-3.03
Srirampuram	.... 8.2	5.56	26.84	-32.41	1.25	-12.25		
HGR I	.... -1.34	-41.77	-92.54	52.63				
HGR II	.... 5.38	-35.71	-25.8	48.86				
Kumara Park	.... -3.81	-18.19	-2.09	5.846				
LLR	.... 8.31	0.854	4.2	2.646	-6.4	0.521	—	—
Chicklalbagh	.... 7.608	-8.98	-14.53	-10.45	-10.18	-4.66	—	—
B. Park I	.... 1.597	-6.2	-0.194	55.93	-9.75	10.32	—	—
B. Park II	.... 5.93	8.98	0.409	-9.437	-10.07	10.966	—	—
Basavanagudi	.... -9.47	71.64	21.58	-59.476	-33.62	12.06	} 13.2	41.31
Chamarajpet	.... -2.345	73.13	18.74	-47.98	-22.08	-11.5		
V. V. Puram	.... 15.31	102.00	-11.75	-49.31	-22.8	30.22		
Mountjoy	.... 22.81	49.24	213.27	45.6	22.74	43.41		
M. B.	.... 8.1	1.05	23.76	-42.06	0	-35.5	0.293	-29.11
C. L. R.	.... 5.13	8.33	3.27	5.56	0	-36.55	316.1	-67.4
Ulsoor	.... 19.48	111.35	6.76	-66.970	0	-34.63	13.97	-4.19
Indiranagar	.... 7.35	6.76	-22.98	79.59	0	-37.03	32.35	20.12
J. B. Nagar	.... -0.92	42.02	3.37	99.42	0	0.08	11.25	-11.07
Rajajinagar	.... 8.92	-1.95	-18.45	12.44	-0.988	0.037		
W. C. Road	.... 3.51	5.06	14.83	6.85	0.32	31.69		
Vijayanagar	.... -13.27	-18.28	9.09	-16.15	3.57	-0.604		

**TABLE-13**  
**Percent Rate of increase in consumption/connection in various Service Stations**

Service Station	Rate of Increase/Decrease						
	Domestic		Non-Domestic		Public Fountains		
	81-82	82-83	81-82	82-83	81-82	82-83	
Malleswaram	....	-2.678	0.895	-9.302	17.948	-7.33	1.458
Sriramapuram	....	1.134	5.748	17.31	-24.14	1.252	-1.224
HGR I	....	-14.11	-8.98	-53.62	362.89		
HGR II	....	-4.57	-36.07	-37.28	149.34		
Kumara Park	....	-5.14	11.84	-3.08	333.34		
LLR	....	5.4	1.3	+5.71	0.704	-6.43	0.523
Chicklalbagh	....	7.213	-10.11	-19.81	-9.38	-7.01	-0.567
B. Park I	....	3.7	-14.7	-2.127	58.69	-6.61	-0.649
B. Park II	....	2.7	9.06	-3.02	-12.33	-6.6	-0.715
Basavanagudi	....	-11.77	68.8	21.613	-50.19	-33.6	-12.06
Chamarajpet	....	-6.666	63.65	18.55	-38.048	20.2	-24.62
V. V. Puram	....	13.54	89.55	-11.75	-53.65	-28.8	27.5
Mountjoy	....	16.31	38.69	208.5	256.75	22.74	21.49
M. B.	....	3.76	-5.6	23.27	-42.29		-37.15
C. L. R	....	1.39	-4.18	-1.5	-1.76		-34.16
Ulsoor	....	15.5	106	2.906	-68.25		-39.58
Indiranagar	....	0.63	-0.67	-23.78	41.15		-31.5
Rajajinagar	....	3.21	-1.12	-10.04	1.62	-0.986	-0.036
J. B. Nagar	....	-21.15	12.18	3.37	99.43		0.08
W. C. Road	....	-17.74	-10.44	1.68	-9.77	-0.691	-1.231
Vijayanagar	....	-21.38	-16.97	8.77	24.15	-1.4	33.38

(Details for Sub-division No. 5 are not available)

**TABLE-14**  
**Per Capita Consumption of Domestic Water Supply in**  
**various service stations in 1983**

Service Station		No. of persons per connection	Domestic Consumption per person (litre/day)
No.	Name		
1A	Malleswaram	15.08	66.46
1B	Srirampuram	25.83	36.56
1C	Yeshwantpur	21.47	34.20
2A	Kumara Park	18.11	58.58
2B	HGR I	17.24	34.49
2C	HGR II	21.46	24.02
2D	Gangenahalli	15.51	35.08
3A	LLR	25.68	45.84
3B	Chiklalbagh	22.51	27.66
3C	B. Park I	19.49	38.99
3D	B. Park II	27.93	35.03
4A	Chamarajpet	31.8	41.89
4B	V. V. Puram	15.68	101.16
4C	Mountjoy	15.29	68.96
4D	MNK Part	12.48	112.64
5A	Byrasandra	22.28	43.07
5B	Banasankari	17.37	44.66
5C	Jayanagar	25.52*	39.71
5D	Koramangala	27.82	25.75
5E	Sarakki	*	*
6A	M. Betta	26.78	34.33
6B	J. Market	16.47	55.22
6C	Ulsoor	17.22	104.17
6D	Indiranagar	6.97	119.53
6E	J. B. Nagar	8.4	63.87
7A	W. C. Road	10.45	49.51
7B	Rajajinagar	9.61	90.01
7C	Vijayanagar	11.07	66.33
7D	Magadi Road	39.30	20.04

\*The figures for 5C include 5E also

TABLE-15

**Frequency Distribution of Per Capita Domestic Consumptions**

Category	Range of Per Capita Consumption	No. of Stations	Percentage of stations	Cumulative percentages
1	< 30 lit/day	4	14.286	14.286
2	30-40 „	8	28.871	42.857
3	40-50 „	5	17.857	60.714
4	50-60 „	2	7.143	67.857
5	60-70 „	4	14.286	82.143
6	70-80 „			82.143
7	80-90 „			82.143
8	> 90 „	5	17.857	100.000
All		28	100.00	
Average per capita consumption ....				48.24 litres/day
No. of service stations with less than average consumption ....				16 (57.14%)

TABLE-16

**Distribution based on Water Consumption**

Category	Domestic Consumption (MLD)	Percentage of consumption	Cumulative percentages
1	10.03	7.45	7.45
2	37.744	28.03	35.48
3	23.678	17.59	53.07
4	10.414	7.73	60.80
5	19.907	14.79	75.59
6	—	—	—
7	—	—	—
8	32.867	24.41	100.00
All	134.64	100.00	100.00

TABLE-17  
Cumulative Distribution based on Population

Category	Population (1000)	Percent	Cumulative Percent
1	414	14.83	14.83
2	1039	37.23	52.06
3	541	19.38	71.44
4	185	6.63	78.07
5	297	10.64	88.71
6	—	—	—
7	—	—	—
8	315	11.29	100.00
<b>Total</b>	<b>2791</b>	<b>100.00</b>	<b>100.00</b>

Population below average consumption .... 1925000 (68.91%)

TABLE-18  
Pipe lengths in Different Divisions

Sub- Division	Trunk	Pipe length in Kms.			Total
		Feeder	Sub-feeder	Distribution	
1	16.9	35.9	23.2	194.3	
2	21.5	19.1	18.3	136.9	
3	30.8	27.3	31.1	213.9	
4	20.9	14.8	18.0	89.8	
5	18.0	105.6	34.3	168.0	
6	19.6	43.3	105.1	147.0	
7	14.8	44.2	132.0	112.2	
<b>Total</b>	<b>142.5</b>	<b>290.2</b>	<b>362.0</b>	<b>1062.1</b>	<b>1856.8</b>

**TABLE-18 (a)**  
**Details of pumping of water into Bangalore city (transmission only)**

Sl. No.	Place	Contract demand (1983) KVA	Maximum demand (1983) KVA	Maximum demand (1984) KVA	Energy (1984) Million units/month	Charges (1984) Million rupees/month
1	T. K. Halli	7095	6510	8220	4.46	1.908
2	Harohalli	8129	5340	6975	3.81	1.629
3	Tataguni	6629	6285	7050	3.85	1.648
4	T. G. Halli	6967.5	6147.5	5570.2	2.91	1.274
5	Tavarekere	2021	2175	2028	1.14	0.493
<b>TOTAL</b>		<b>30841.5</b>	<b>26457.5</b>	<b>29843.2</b>	<b>16.17</b>	<b>6.952</b>

**TABLE-19**  
**Water use in Bangalore Dairy per day**

**1. Washing**

Tankers	....	4000	
Cans	....	16615	
Bottles	....	150000	
Crates	....	76800	
Milk Storage tanks	....	14400	
Cream Storage tanks	....	3500	
Ghee bottles	....	5000	
Cans and bottles	....	3500	
<b>Total (litres/day)</b>	...	<b>273815</b>	<b>(36.5%)</b>

**2. Floor washing and cleaning**

Bottling section	....	100000	
Milk processing section	....	48000	
Butter section	....	20000	
Ghee section	....	1600	
Miltone section	....	3000	
Powder section	....	2000	
<b>Total (litres/day)</b>	....	<b>174600</b>	<b>(23.3%)</b>

**3. Process use**

Water for milk powder	....	73000	
Butter churns	....	15940	
Miltone	....	4400	
Total (litres/day)	....	<u>93340</u>	(12.4%)

**4. Others** .... 118245 (15.8%)**5. Domestic (canteen, offices)** .... 90000 (12%)

Total (litres/day)	....	<u>750000</u>	
--------------------	------	---------------	--

TABLE-20

Type of vehicle	No. of Vehicles	Total quantity of water required to clean the vehicles once (lakh litres)
Motor cycles	.... 167416	251.1
Cars	.... 37126	111.4
Jeeps	.... 4193	12.6
Auto Rickshaws	.... 12010	24.1
Taxis	.... 1706	5.1
Lorries	.... 11586	208.6
<b>TOTAL</b>	....	<b>612.9</b>

**TABLE-21**  
**Water Consumption in Public Fountains Surveyed**

Sl. No.	Area	No. of houses	No. of persons	Quantity L/day	Distance (ft) from PF			Hours of supply daily	Pressure of water (time to fill 10 litres) (secs.)	
					Max	Min	Avg.			
1	Gavipura	....	40	217	13975	240	10	88.2	10	25.5
2	K. G. Nagar	....	22	102	5510	300	10	112.0	11	45-250
3	Gavipura	....	40	195	7393	340	10	133.5	9	42.5
4	Tilak Nagar	....	62	428	9110	285	15	170.0	15	39.55
5	Ulsoor*	....	39 + 21 (60)	290	6400	250	10	113.6	6.50	35.0
6	Ulsoor	....	23	119	3660	170	20	79.5	5	42.4
7	RPC Layout	....	25	142	9130	100	10	50.0	24	45.5
8	RPC Layout	....	26	147	10040	100	20	46.0	24	37.8
9	Chiklalbagh	....	6	40	430	225	10	17.4	2	165.0
10	Kilari Road	....	18	114	2750	150	20	67.0	8.25	44.0
11	Bapuji Nagar	....	16	97	7150	360	15	143.0	4	27.0
12	Yeshwantpur	....	24	122	2760	160	50	106.0	5	60.0
13	Govindaraj Nagar	....	30	135	10380	260	70	163.0	17	23.9

TABLE-22

## Average per capita consumption in the Public Fountains Surveyed

Sl. No.	Location		Actual per capita in litres/day	Maximum per capita possible
1	Gavipura Guttahalli	....	69.87	70.6
2	Kempe Gowda Nagar	....	54.00	65.00
3	Gavipura	....	37.89	39.1
4	Tilaknagar	....	21.3	23.4
5	Ulsoor	....	22.0	23.05
6	Ulsoor	....	30.75	35.67
7	R. P. C. Layout	....	64.3	66.78
8	R. P. C. Layout	....	68.3	71.17
9	Chiklalbagh	....	10.75	11.0
10	Kilari Road	....	24.00	28.72
11	Bapuji Nagar	....	73.00	82.15
12	Yeshwantpur	....	22.62	24.6
13	Govindaraja Nagar	....	76.8	111.0
Average		....	44.27	50.21

**TABLE-23**

**Water Consumption in Slums**

Sl. No.	Location	No. of huts	Popula- tion	No. of hh sampled	Source of water	Source of drinking water	Distance of source (Km)	Percapita Consum- ption L/d
1	Railcoach, 2nd stage, Bangalore-560 075	178	1220	40	Wells (8 Nos.)	BWSSB	0 6	16.6
2	Yeshwantpur	16	84	all	P. F.	P. F.	Nearby	16.00
3	Mysore Road Bangalore-560 026	103	650	25	P. F.	P. F.	0 06	23.00
4	Magadi Road (close to BWSSB service station)	92	400	15	P. F. (3 Nos )	P. F.	0 00	18 33
5	5th Block, Rajajinagar	300	1975	25	P. F. (4 Nos.)	P. F.	0 00	20.00

**TABLE-24**  
**Annual Rainfall details of Bangalore (in mm)**

Year	Rainfall	Year	Rainfall
1927	603	1955	795.8
28	673.3	56	1121.4
29	789.7	57	762.3
30	991.4	58	1282.0
31	641.1	59	969.6
32	1090.4	60	890.6
33	1049.0	61	881.4
34	628.4	62	1052.7
35	1101.9	63	1036.8
36	771.4	64	1191.6
37	830.1	65	692.0
38	799.8	66	1206.1
39	895.6	67	760.1
40	924.6	68	868.6
41	861.8	69	1197.9
42	829.6	70	1024.3
43	1240.8	71	921.7
44	1009.9	72	894.5
45	587.8	73	888.9
46	1042.2	74	954.5
47	910.6	75	1059.0
48	1001.8	76	770.0
49	1070.4	77	1003.8
50	802.6	78	803.9
51	904.5	79	1231.9
52	812.0	80	781.4
53	1202.2	81	855.7
54	873.2	82	760.4

**TABLE-25 Tanks in Bangalore**

Year	Number in Corporation area	Number in BDA area	Number in the proposed BMRDA area
1931	26	115	
1971	17	78+(17)	60(+78+17)
1981*	5	11+(5)	11+(5+3)

\*About 30 tanks are present but 14 of them have shrunk to a very small size.

**Number of tanks as per BDA figures**

Number of tanks in the 18 districts of BDA	....	114
Number of ponds	....	106

TABLE-26

**Names of tanks\* and their positions in 1960 and 1984**

Name	Position in 1960	Position in 1984
1 Abbigere tank		
2 Singapura tank		
3 Hanchipura 1		
4 Hanchipura 2		
5 Kammagondanahalli 1	—	—
6 Kammagondanahalli 2		
7 Tyarakabandakaval	—	—
8 Doddabommasandra	—	—
9 Amrithahalli		
10 Rachenahalli	—	—
11 Malasandra		
12 Hebbal	—	—
13 Nagavara	—	—
14 Nagsettihalli		
15 Mathikere	—	
16 Hennur	—	—
17 Gedalahalli	—	—
18 Kalagondanahalli	—	—
19 Kacharakanahalli		
20 Sankey	—	—
21 Devarajivanahalli		
22 Lingarajapura		
23 Milk Colony		
24 Kurubahalli (1)	—	—
,, (2)	—	—
25 Miller		
26 Seshadripuram		
27 Shivanahalli		
28 Oddarapalya (1)		
(2)		
29 Kamakshipalya	—	—
30 —		
31 Moodalapalya	—	—
32 Ulsoor	—	—
33 Dharmambudi		
34 Sampangi		
35 Agrahara		
36 —		
37 Larypalya	—	—

Name	Position in 1968	Position in 1984
38 Nayandahalli	—	—
39 Deevatige Ramanahalli		
40 Byatarayanapura		
41 Kempambudi	—	—
42 Lalbagh	—	—
43 Vannarpet		
44 Adugodi		
45 Siddapura	—	—
46 Bairasandra	—	—
47 Mistripalya	—	—
48 Chinnagara	—	—
49 Yediyur	—	—
50 Tyagarajanagar	—	—
51 Hosakerehalli	—	—
52 Ittamadu	—	—
53 Chikkakalsandra	—	—
54 Thayappanahalli		
55 Madivala		
56 Sarakki		
57 Javaganahalli		
58 Elachanahalli (1)		
(2)		
59 Gaudanapalya	—	—
60 Arehalli		
61 Uttarahalli		
62 Bikasipura	—	
63 Subramanyapura	—	
64 Bilekahalli		
65 Gubbi	—	—
66 Nagareswara Nagenahall		
67 Kalkere		
68 Channasandra		
69 Banasawadi		
70 Challakere		
71 Horamavu		
72 Varanasi		
73 Bavikaloni		
74 Yerranapalya		
75 Vijnanapura		
76 Krishnarajapura	—	—

Name	Position in 1960	Position in 1984
77 Channasandra		
78 Nagulvapalya		
79 Bayyappanahalli		
80 Bendiganahalli		
81 Byatarayanapura		
82 Pettappakudige		
83 Mahadevpura		
84 Kadramapalya		
85 Jogupalya	—	
86 Malleswarappanapalya		
87 Doddankunte tank	—	—
88 Kodihalli		
89 Challaghatta		
90 Konnenagagrahara		
91 Bellandur	—	—
92 Jakkasandra		
93 Ibbalur		
94 Kagondanahalli (1)		
Kagondanahalli (2)		
95 Devarabasavanahalli		
96 Halanayakanahalli		
97 Junnsandra		
98 Haralur 1		
Haralur 2		
99 Samasundrapalya		
100 Hongasandra		
101 Honalakunte		
102 Ellukunte		
103 Ambipura 1		
Ambipura 2		

Note :— Tanks in Existense. Blank indicates Tanks not existing.

**TABLE-27**  
**Sewerage Flows into Major Valleys**

Sl. No.	Name of the Valley	Quantity of flow after I stage	Quantity after II stage	Quantity after III stage	Total flow
1	V. Valley	122 MLD (27 MGD)	180 MLD (40 MGD)	—	180 MLD
2	K. and C. Valley	162 MLD (36 MGD)	216 MLD (48 MGD)	—	216 MLD
3	Hebbal Valley	—	100 MLD (22 MGD)	—	100 MLD
4	Others	—	156 MLD)	140 MLD	260 MLD
<b>TOTAL ....</b>		<b>284 MLD</b>	<b>652 MLD</b>	<b>104 MLD</b>	<b>756 MLD</b>

TABLE-28

**List of Industries in Bangalore District who are using treated effluent for irrigation/other uses**

Sl. No.	Name of Industry	Quantity of waste water	
		Trade Lpd	Domestic Lpd
1	Indian Telephone Industries, Bangalore.	—	10,00,000
2	Laxman Isola, Bangalore	6,24,000	—
3	Smith, Kline and French Ltd., Bangalore.	1,44,000	42,000
4	Jindal Aluminium, Bangalore	—	13,620
5	Himalaya Drug Co., Bangalore	10,000	8,000
6	Joy Ice Creams, Bangalore	12,400	2,000
7	Karnataka Jewels Ltd., Bangalore	16,000	1,000
8	Alembic Glass Industries, Bangalore	1,40,000	1,15,000
9	Alfred Herbert (India) Ltd., Bangalore	—	11,000
10	Usha Martin Black, Bangalore	135	5,850
11	Senapathy Whiteley Ltd., Bangalore	21,15,350	—
12	Mysore Wine Products Ltd., Bangalore	12,000	—
13	Astra IDL Ltd., Bangalore	1,45,000	—
14	Kamani Metals & Alloys, Bangalore	15,000	15,000
15	Khoday Brewing and Distilling Industries Ltd., (Brewery Division) Bangalore.	1,22,000	—
16	WIDIA India Ltd., Bangalre	—	72,000
17	Suri & Nayar Ltd., Bangalore	—	56,000
18	Grindwell Norton, Bangalore	1,00,000	—
19	CIPLA, Bangalore	30,000	—
20	Bharat Fritz Werner, Bangalore	—	23,500
	<b>Total</b>	<b>34,85,885</b>	<b>13,64,970</b>
	<b>Grand Total</b>	<b>48,50,855</b>	

TABLE-29

## Major Industries in Bangalore who can treat their effluents for reuse

Sl. No.	Name	Quantity Lakh litres / day	
		Trade	Domestic
1	I. T. I.	5.6	18.1
2	B. E. L.	23.0	16.0
3	H. M. T.	34.45	1.35
4	AMCO Batteries	1.12	0.65
5	BHEL Electroporcelains Div	4.0	0.50
6	WIDIA India	0.48	0.72
7	Panyam Cements	1.8	0.37
8	Sreenivasa Textiles	4.0	—
9	Graphite India	1.17	—
10	MICO	2.0	4.5
11	AMCO, Hebbal	0.35	—
12	N. G. E. F.	0.32	4.32
13	ESCORTS	0.75	0.90
14	B. E. M. L.	1.04	4.03
15	Binny	12.36	5.0
16	H. A. L.	7.0	70.0
17	BHEL Control Equipments Div.	1.0	0.6
18	Karnataka Soaps and Detergents	3.5	—
19	M. E. C.	0.4	0.1
20	Grindwell Norton	1.0	—
21	International Instruments	—	0.49
22	Bangalore Dairy	7.5	—
23	Kissan Products	2.67	—
24	I. T. C.	1.14	—
25	U. G.	1.71	—
26	Raja Mills	5.61	—
<b>TOTAL</b>		<b>123.97</b>	<b>127.63</b>
Total		25.16 MLD	

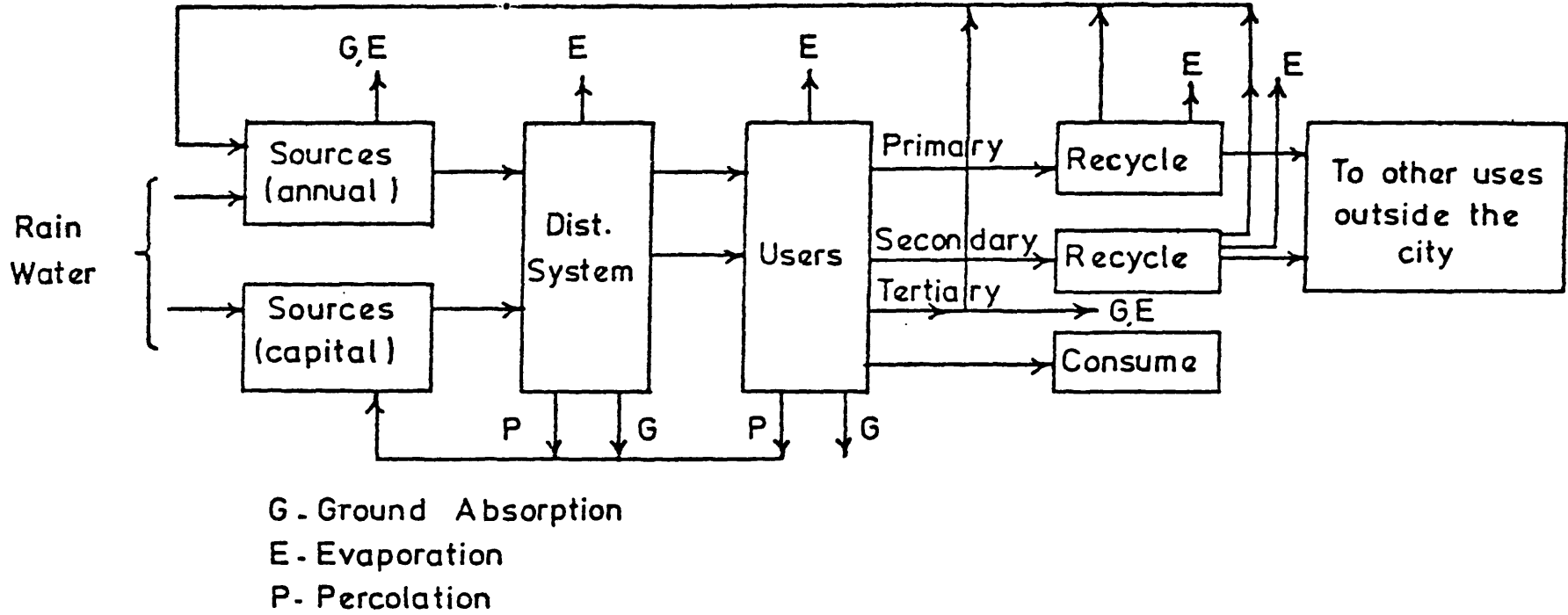

FIG.1. WATER CYCLE IN AN URBAN WATER SUPPLY SYSTEM.

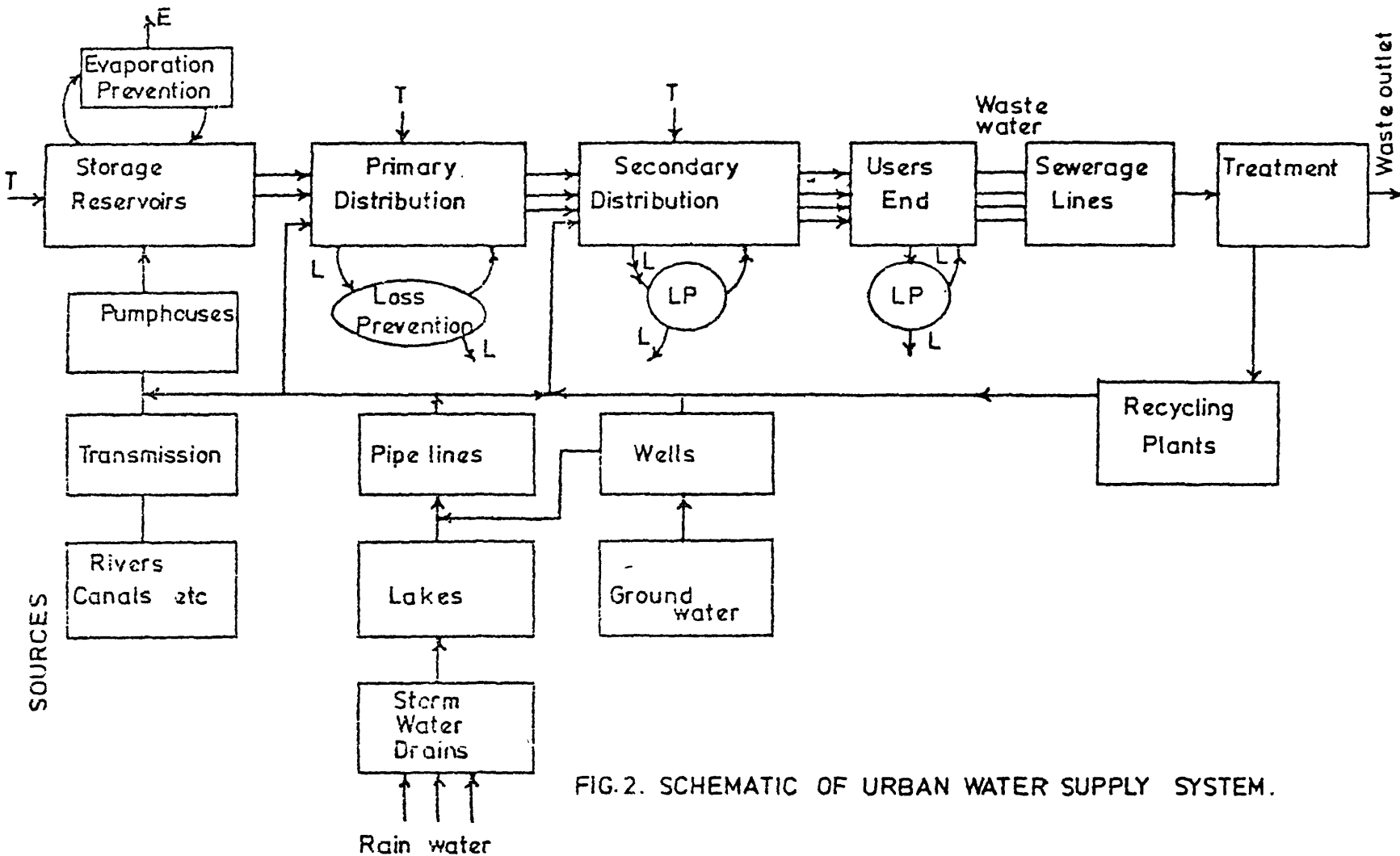

FIG.2. SCHEMATIC OF URBAN WATER SUPPLY SYSTEM.

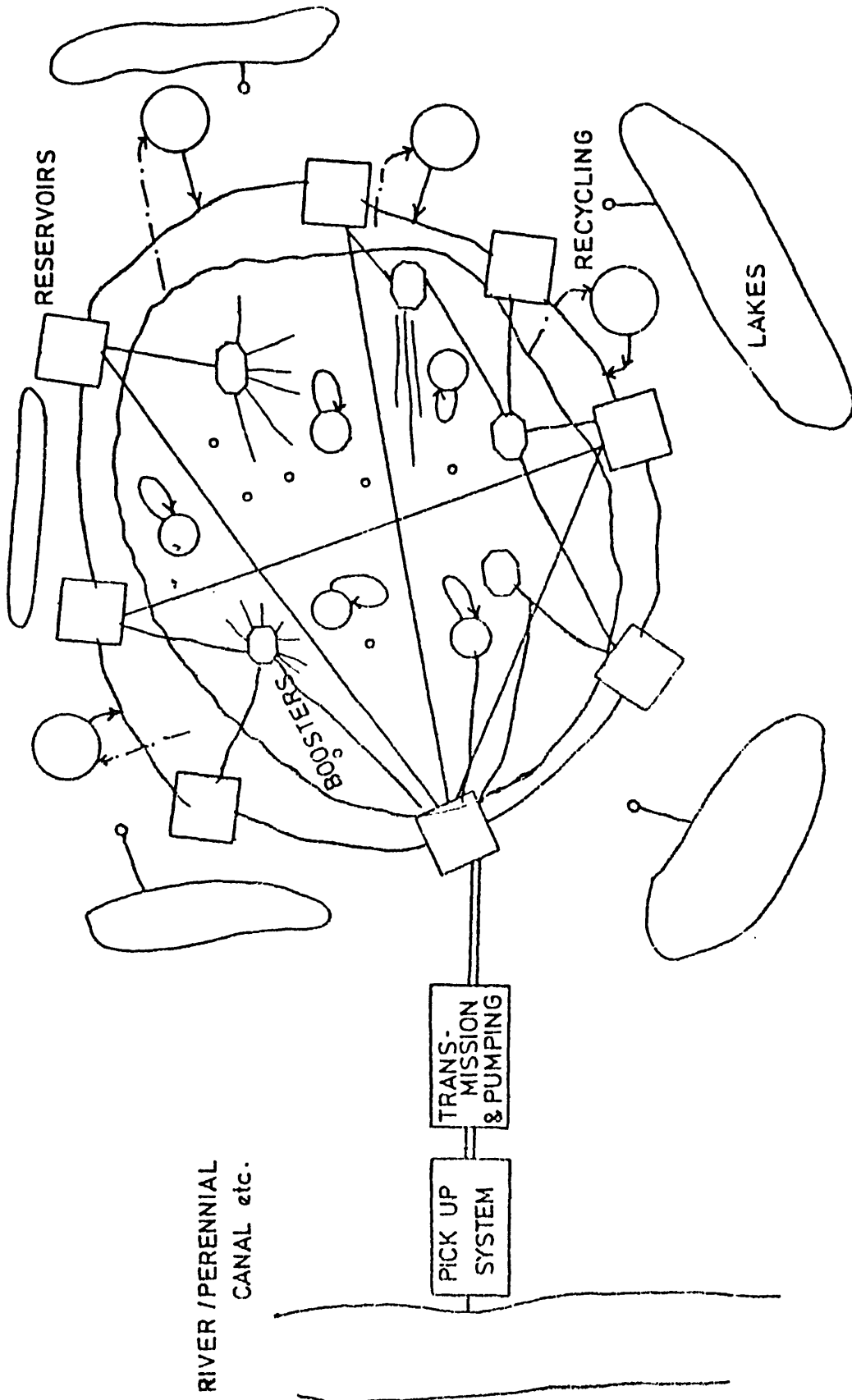

FIG.3. WATER SUPPLY SYSTEMS

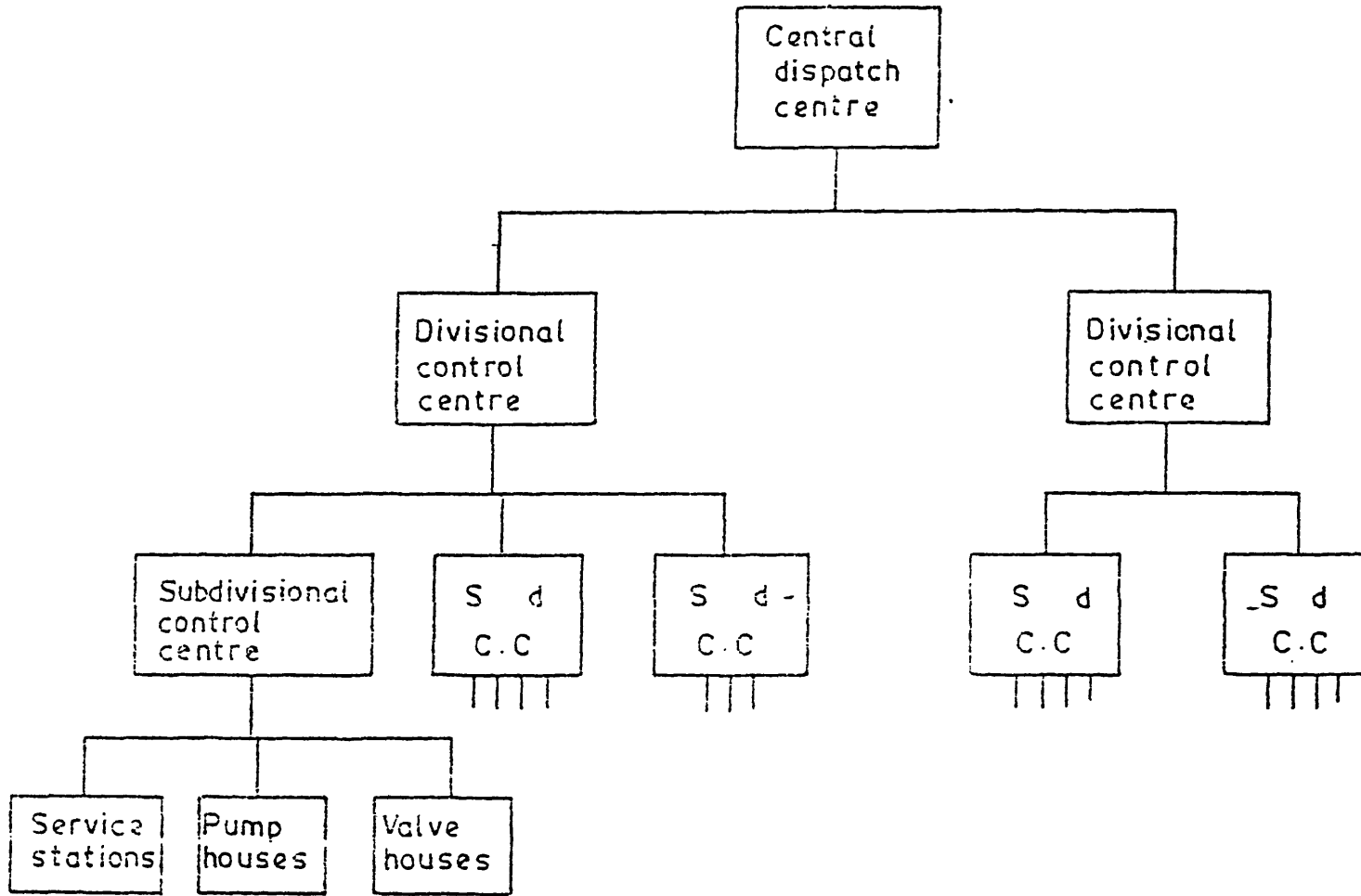

Fig.4 (a)-Schematic of a dispatch computer organization for urban water supply system

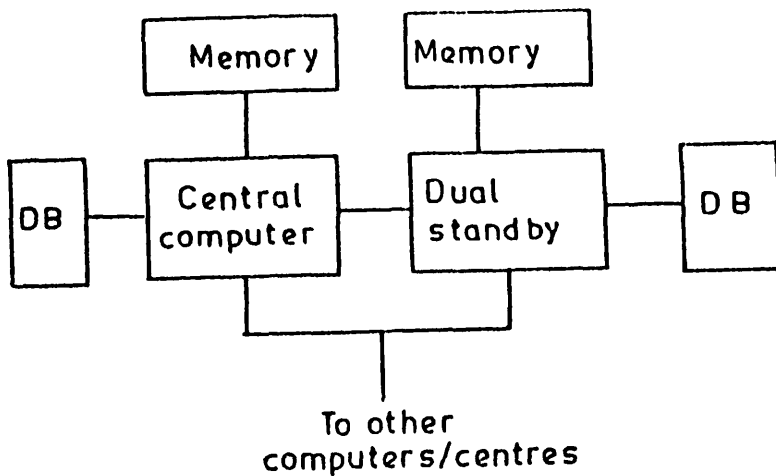

Fig.4 (b) - A dual computer configuration for central dispatch centre

Legend:

Iap - Interactive processor

Cp - Conventional I/O processor

DBP - Data base processor

IP - Input processor

ComP - Communications processor

AP - Associative processor

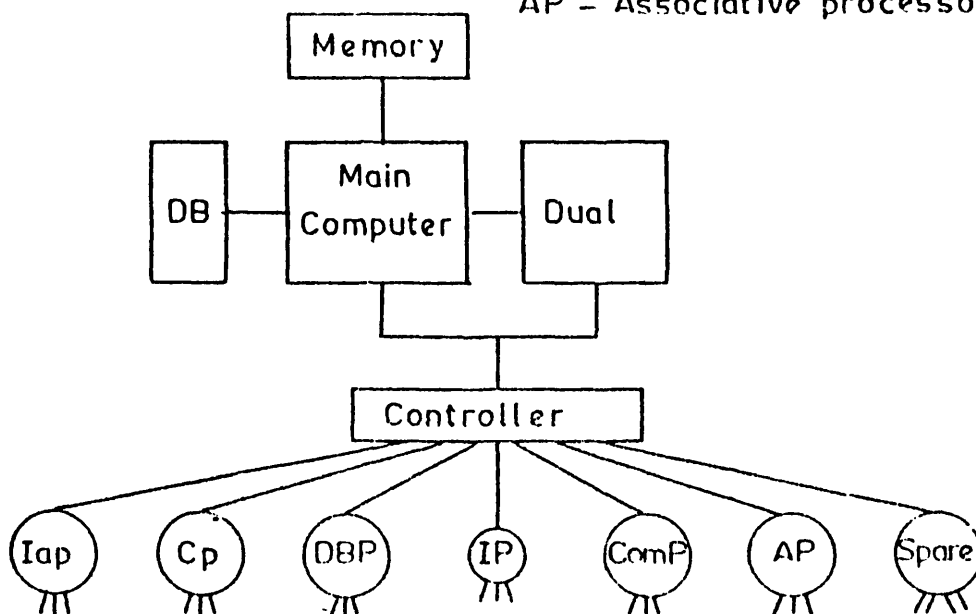

Fig. 4 (d) - A star network configuration for the central dispatch centre

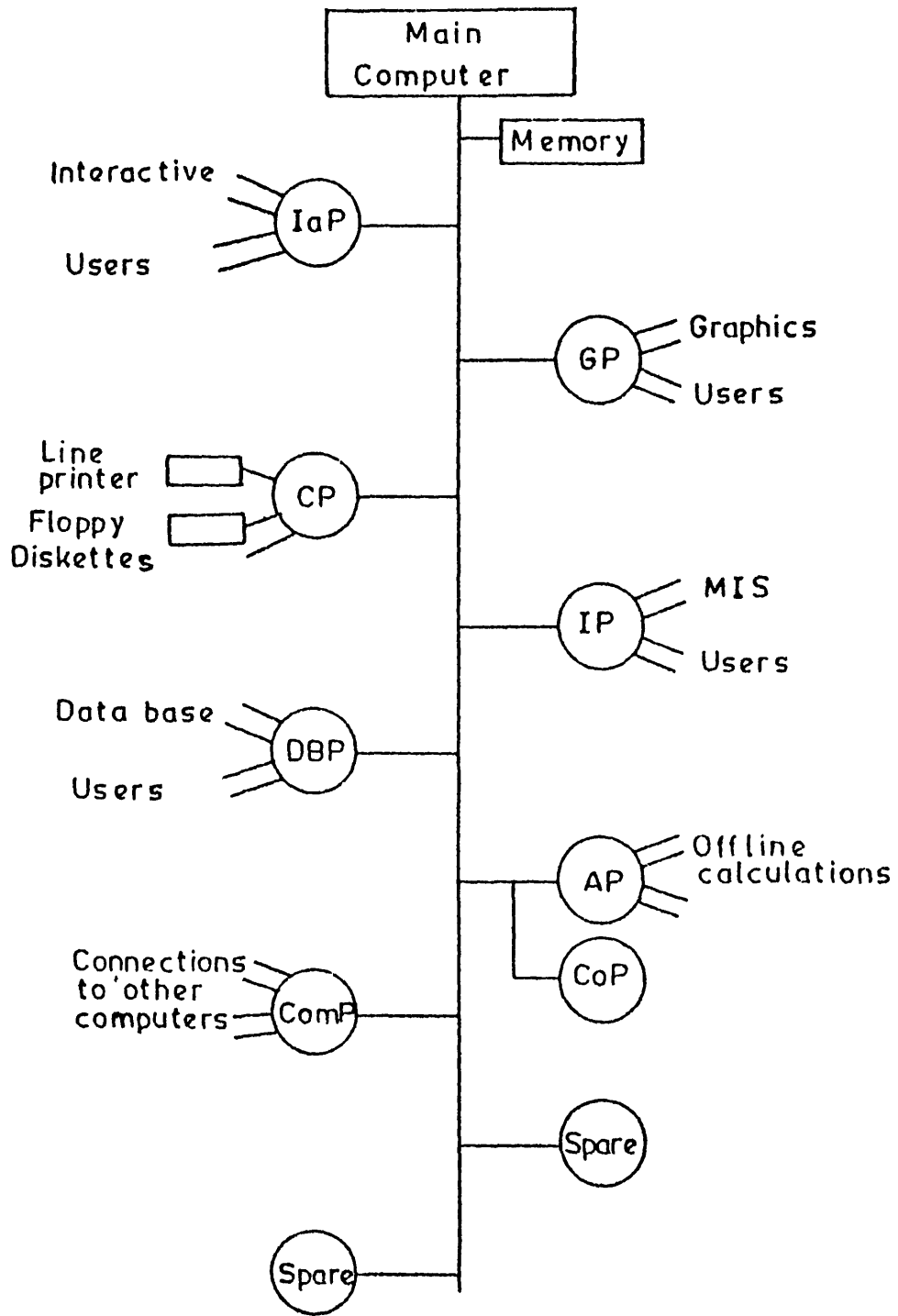

Fig. 4 (c)- A Network configuration for the central dispatch centre

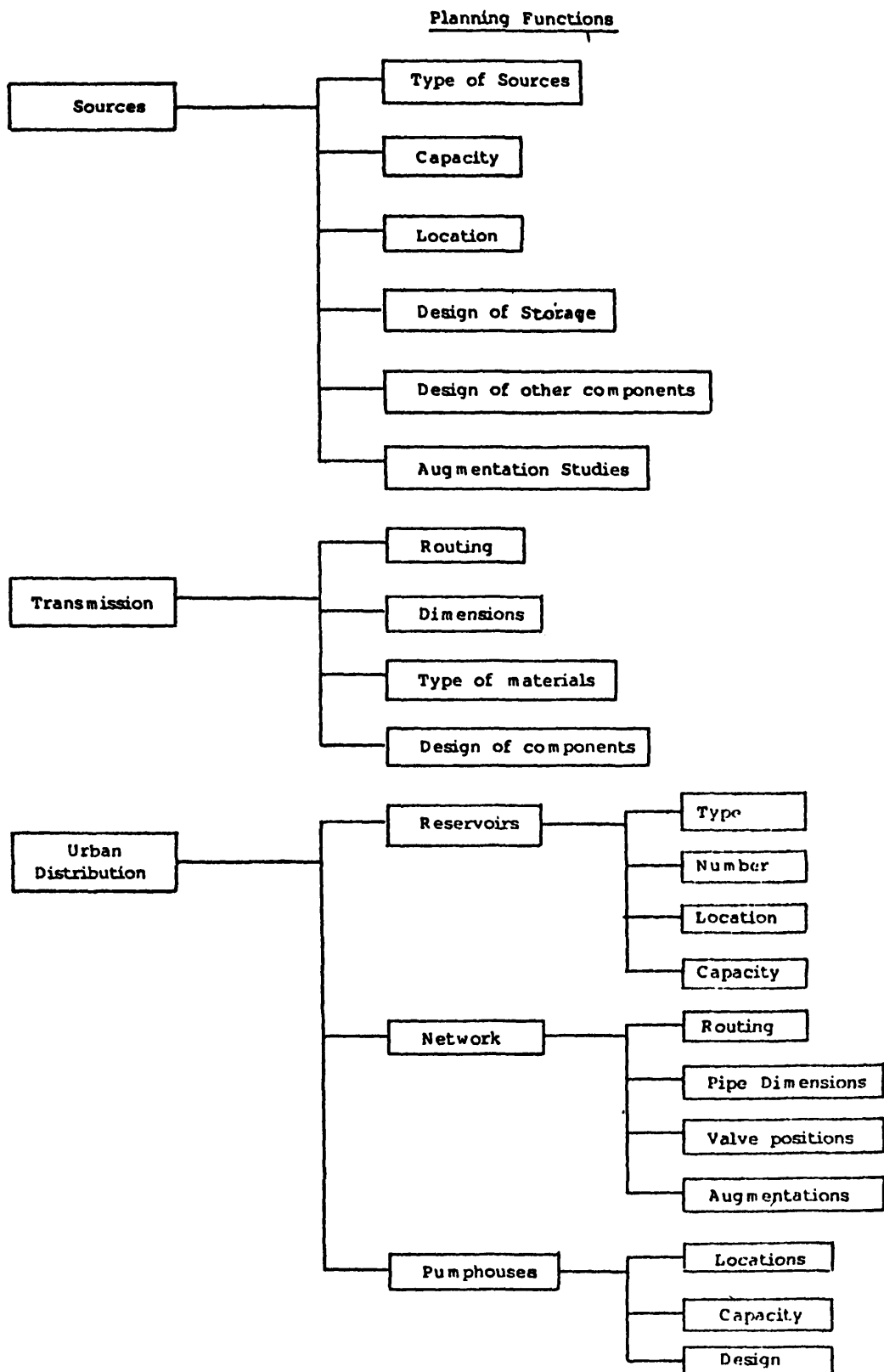

Fig 5(a) Functions of the dispatch centre

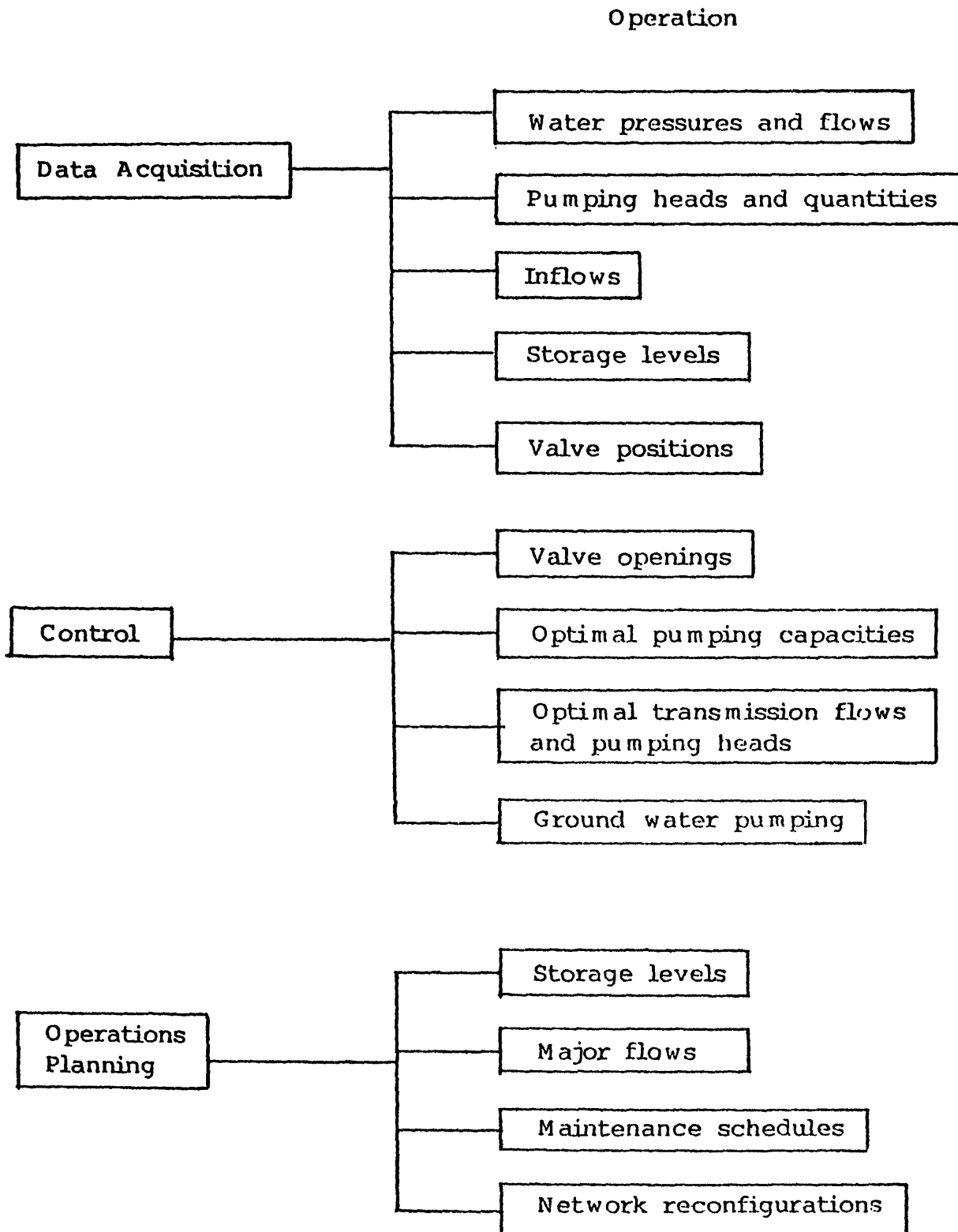

Fig.5(b) Operations functions of the dispatch centre

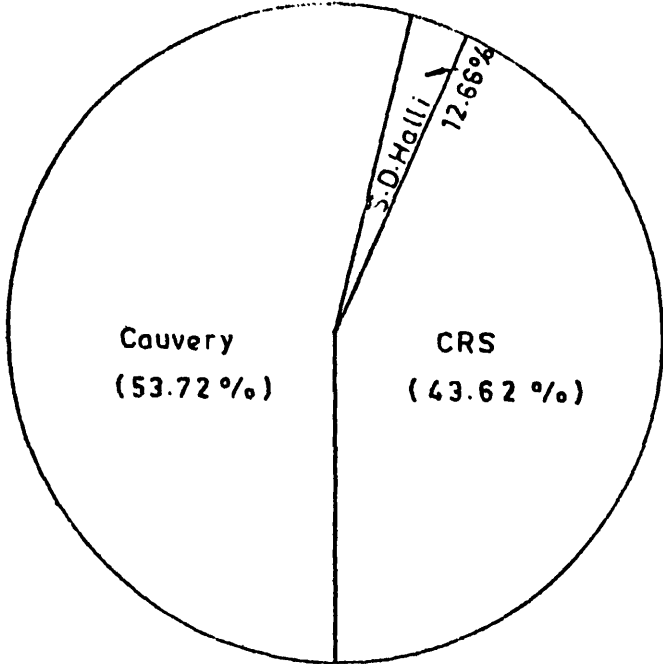

Fig. 6 - Water inflow into Bangalore (1983)

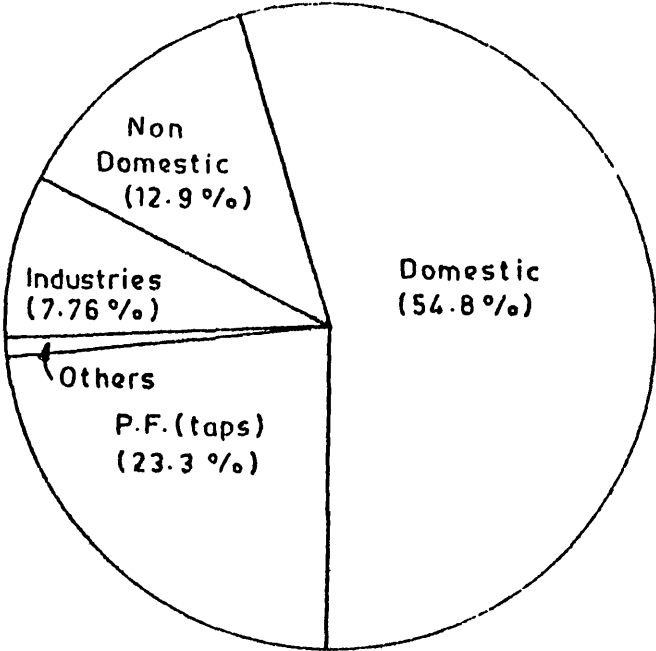

Fig. 7 - Category wise consumption (1983)

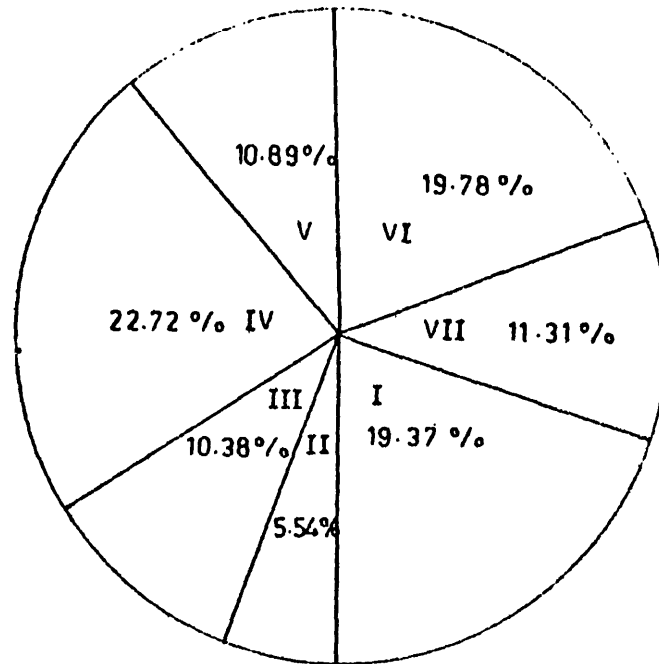

Fig.8 - Consumption in each subdivision (1983)

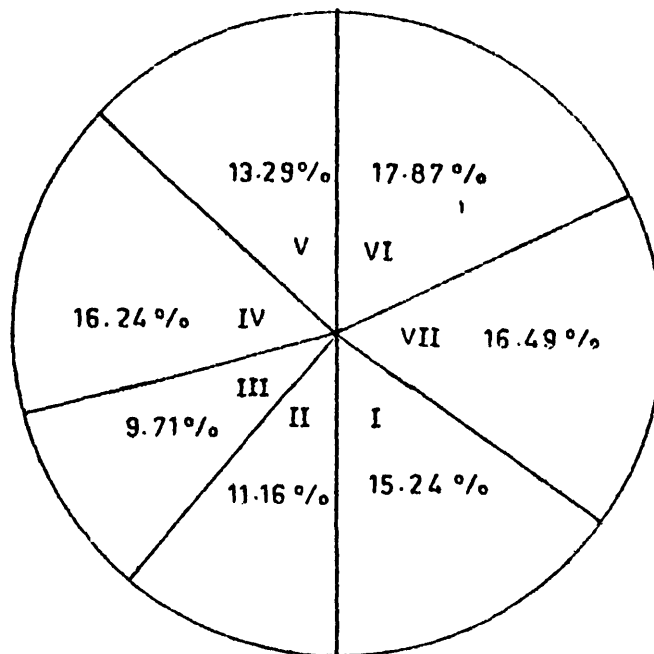

Fig.9 - Number of Domestic connections for each sub division

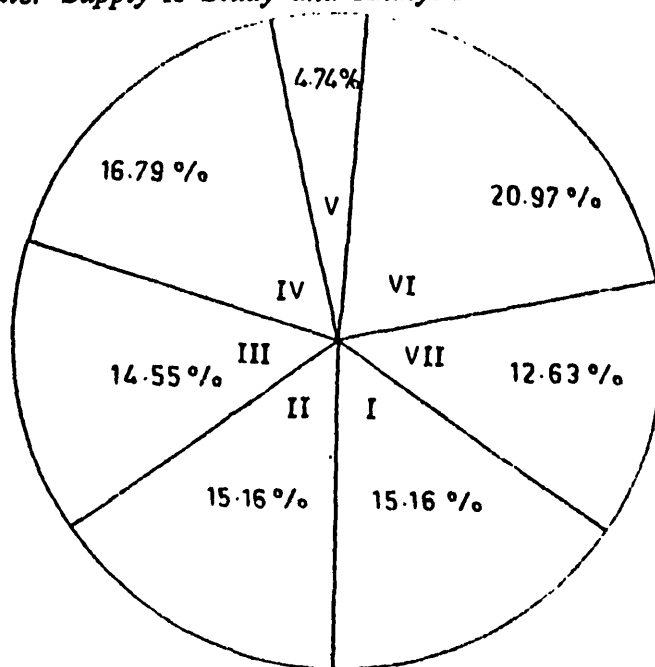
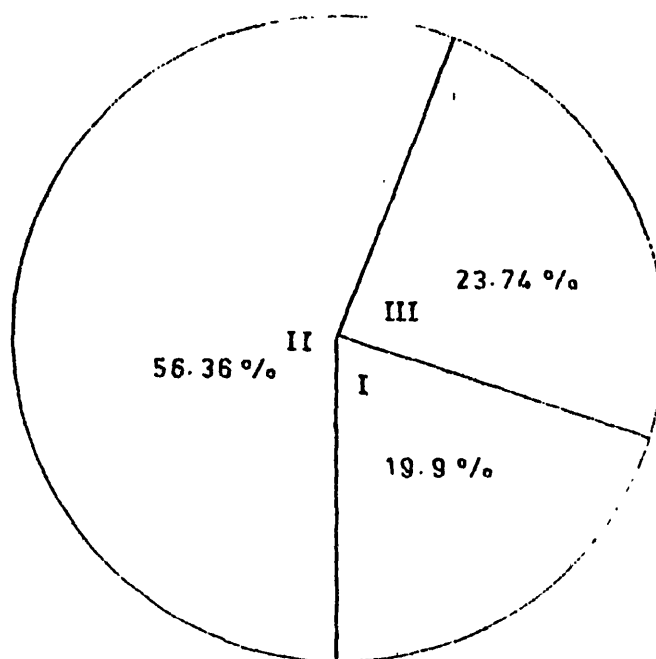
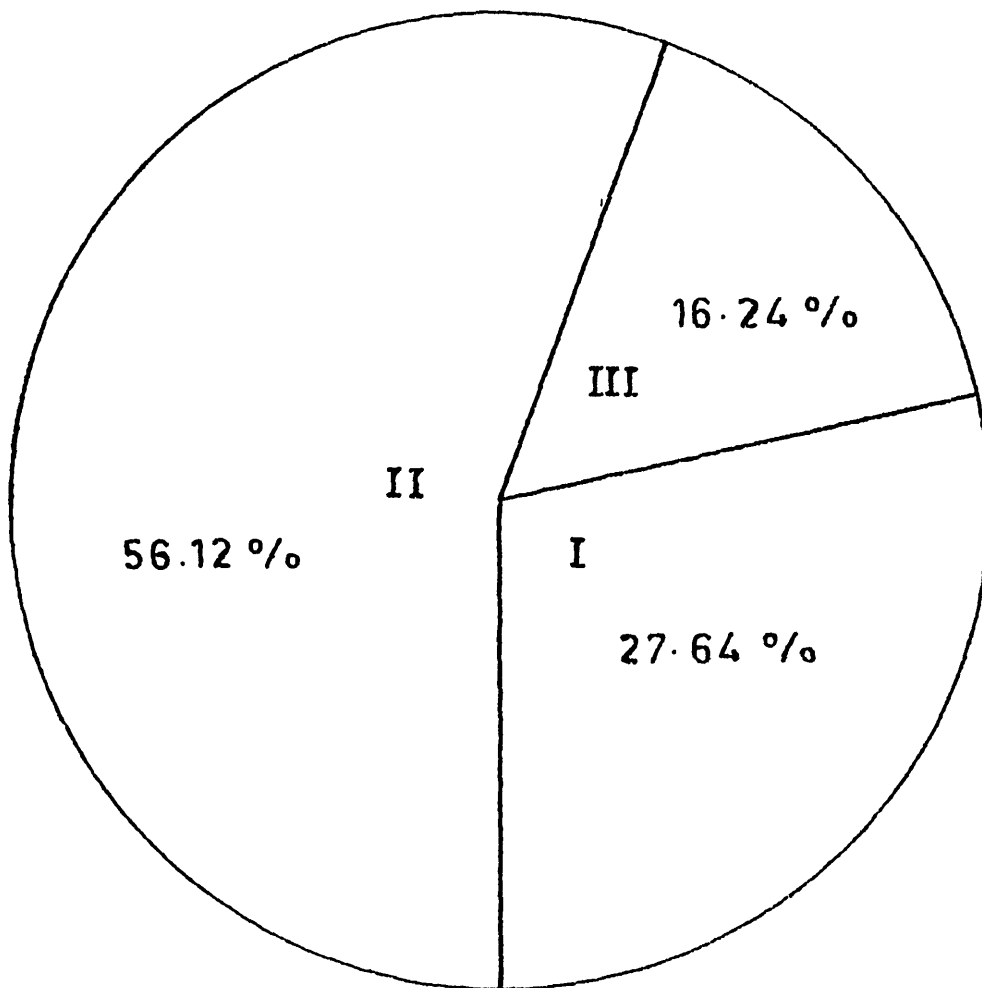

Fig. 10 - Number of public fountains (taps) in each subdivision.



Group	Consumption per connection
Group 1	20 - 22 kl/month
Group 2	25 - 30 "
Group 3	> 30 "

Fig. 11 (a) - Domestic consumption for various groups (based on consumption per connection)



Group	Consumption per connection
Group 1	20 - 22 kl/m
Group 2	25 - 30 kl/m
Group 3	> 30 kl/m

Fig. 11 (b) - Number of domestic connections for each group (Group classified according to consumption per connection)

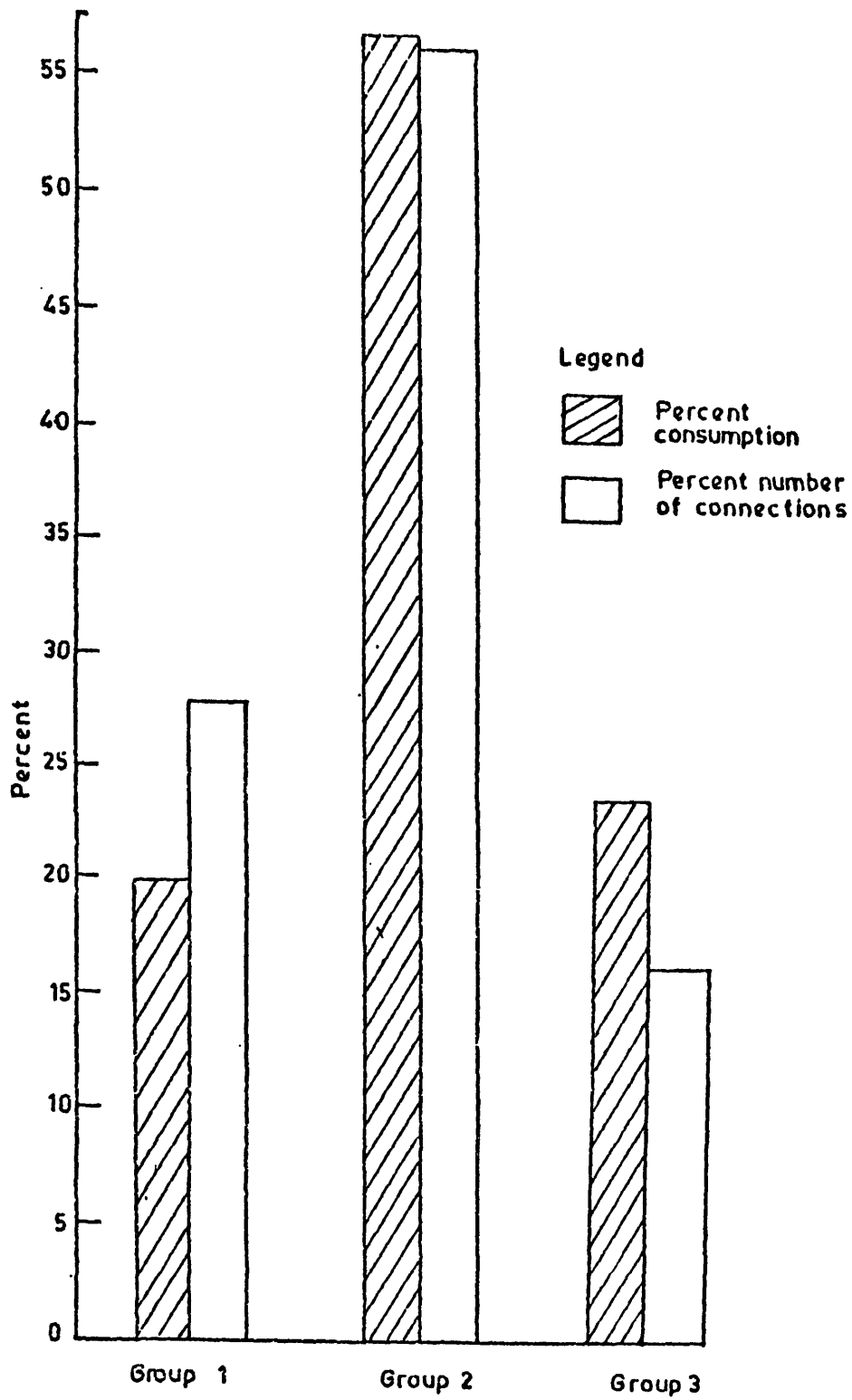
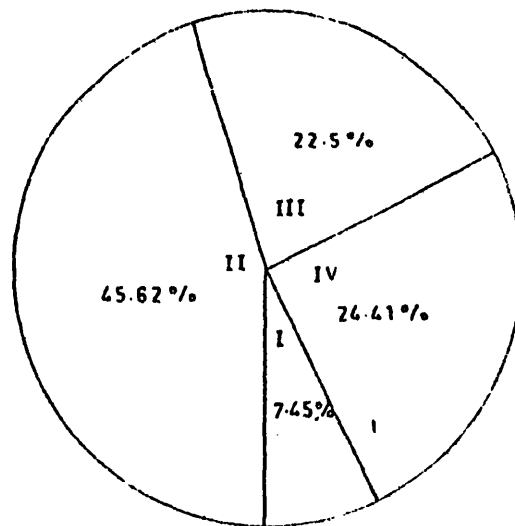
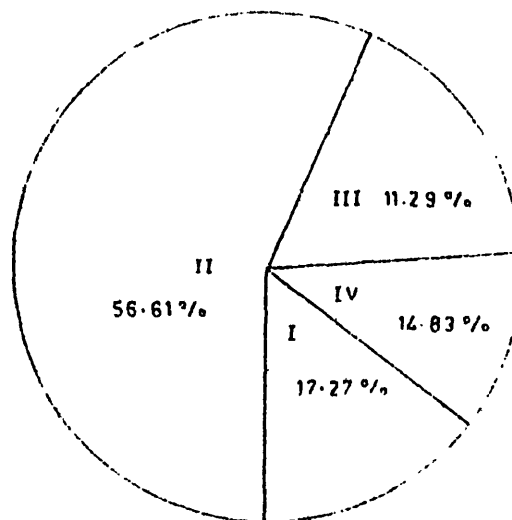

Fig.11 (c) - Categorywise domestic consumption and number of connections (both percentages)



Category	Per capita consumption litres / day
I	< 30
II	30 - 50
III	50 - 70
IV	> 90

Fig.12 (a) - Domestic consumption for different categories (based on consumption per capita)



Category	Per capita consumption litres / day
I	< 30
II	30 - 50
III	50 - 70
IV	> 90

Fig.12 (b) - Population for different categories (based on consumption/capita)

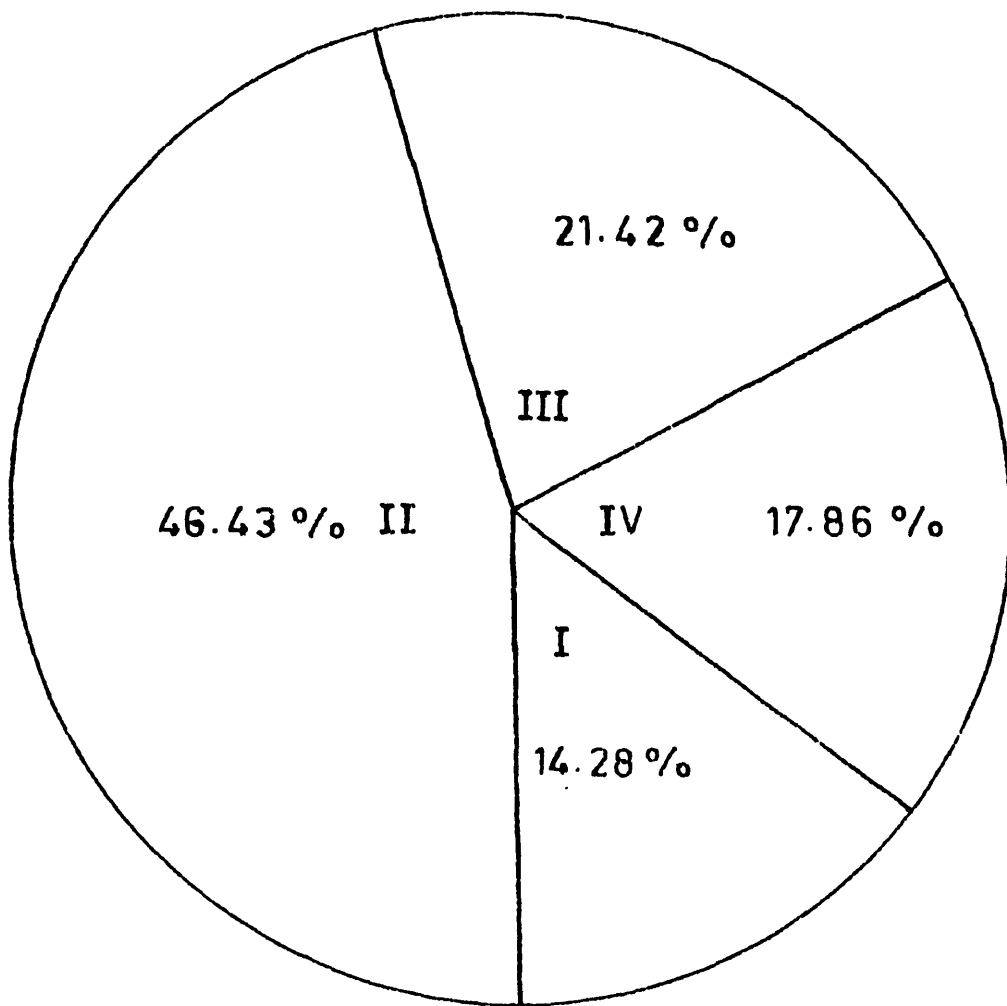

Category	Per capita consumption litres /day
I	< 30
II	30 - 50
III	50 - 70
IV	> 90

Fig. 12 (c)-Number of service stations in each category (based on consumption per capita)

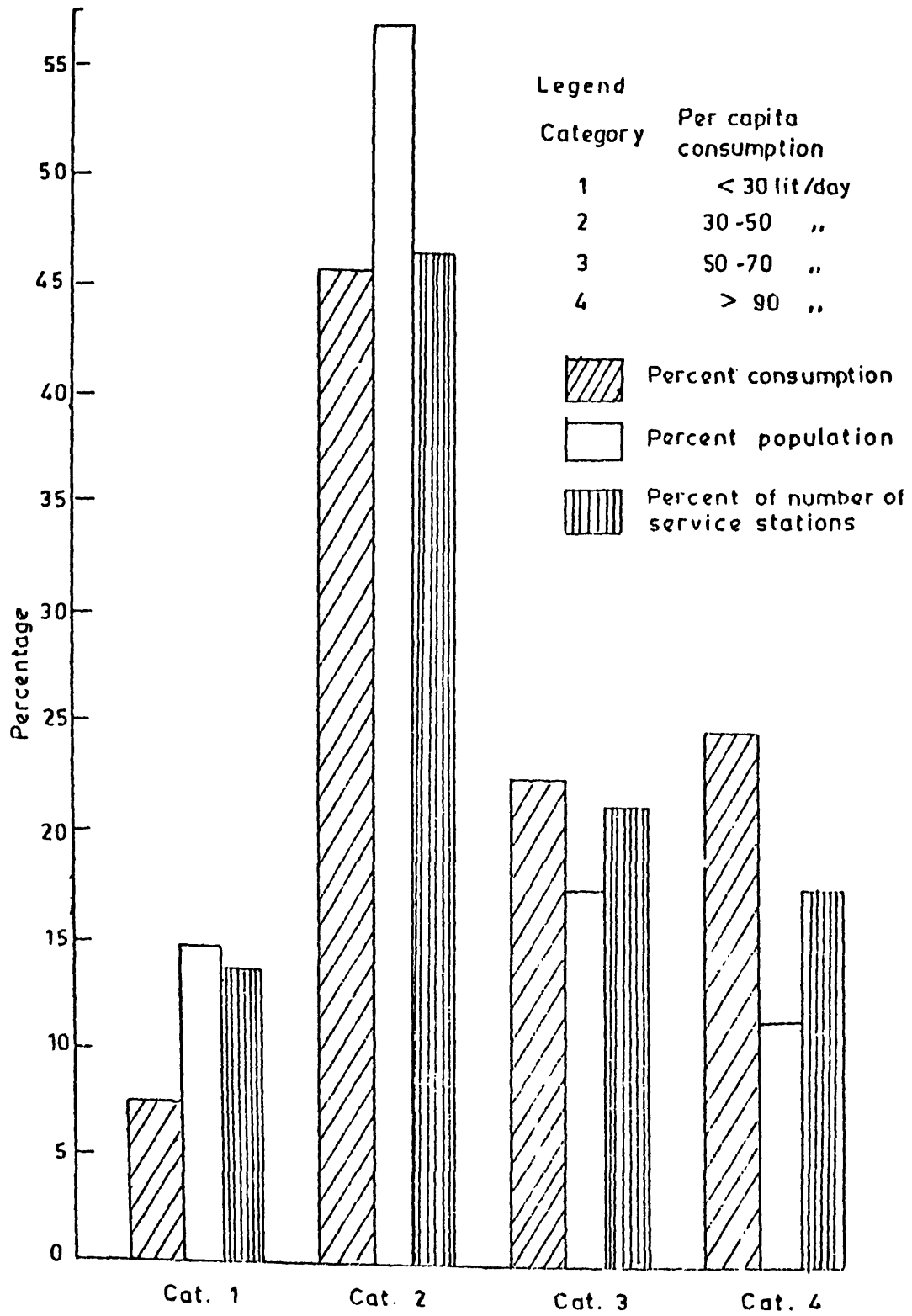
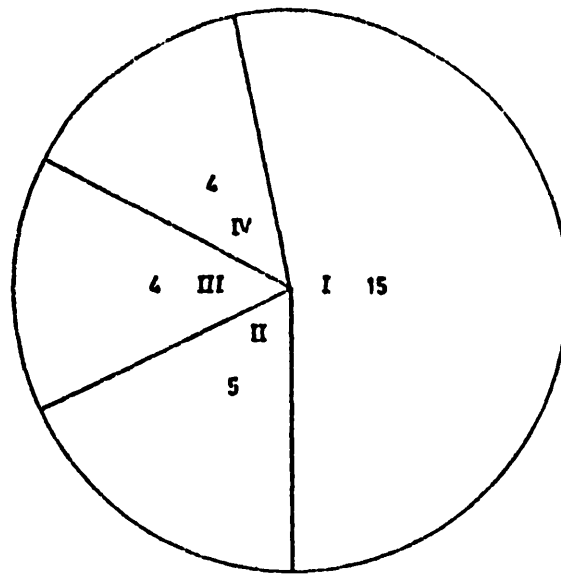

Fig.12 (d) - Domestic consumption, population and number of service stations



Category	Standard deviation
I	< 10%
II	10% - 20%
III	20% - 30%
IV	> 30%

Fig.13 - Number of service stations categorized by standard deviations in water consumptions

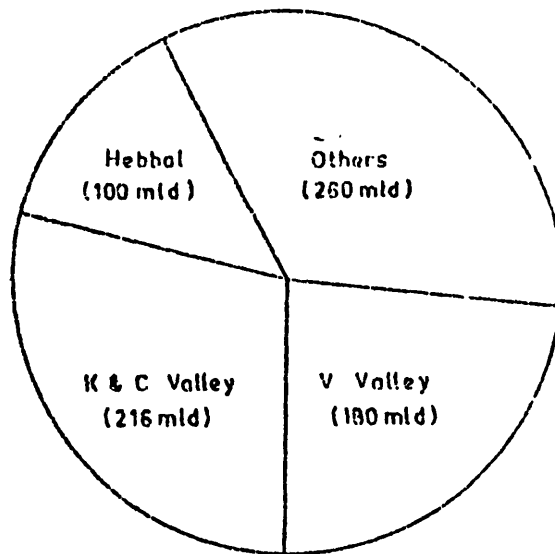

Fig.14 - Sewerage treatment in different Valleys

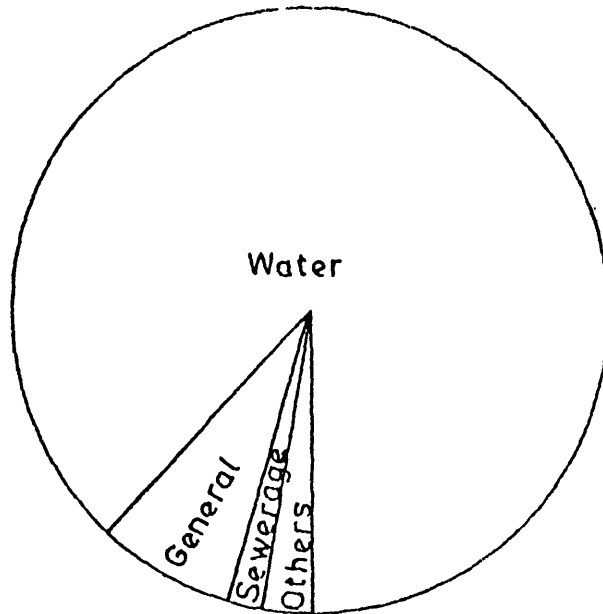

Fig.15 (a) Receipts for 1981-82

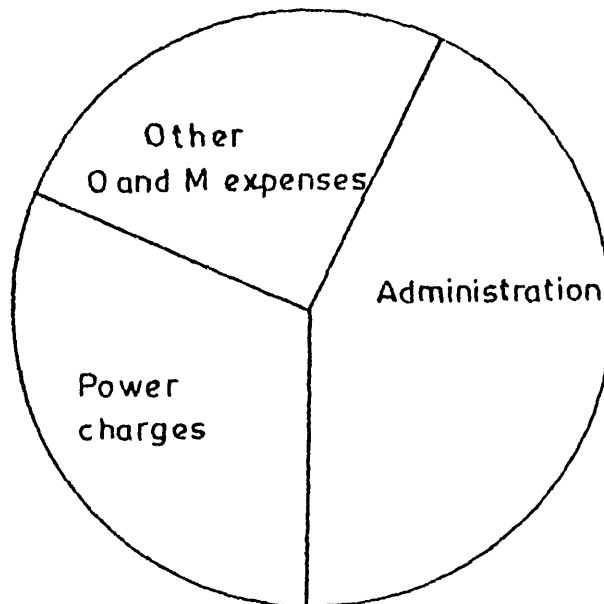

Fig.15 (b) Expenditure for 1981-82

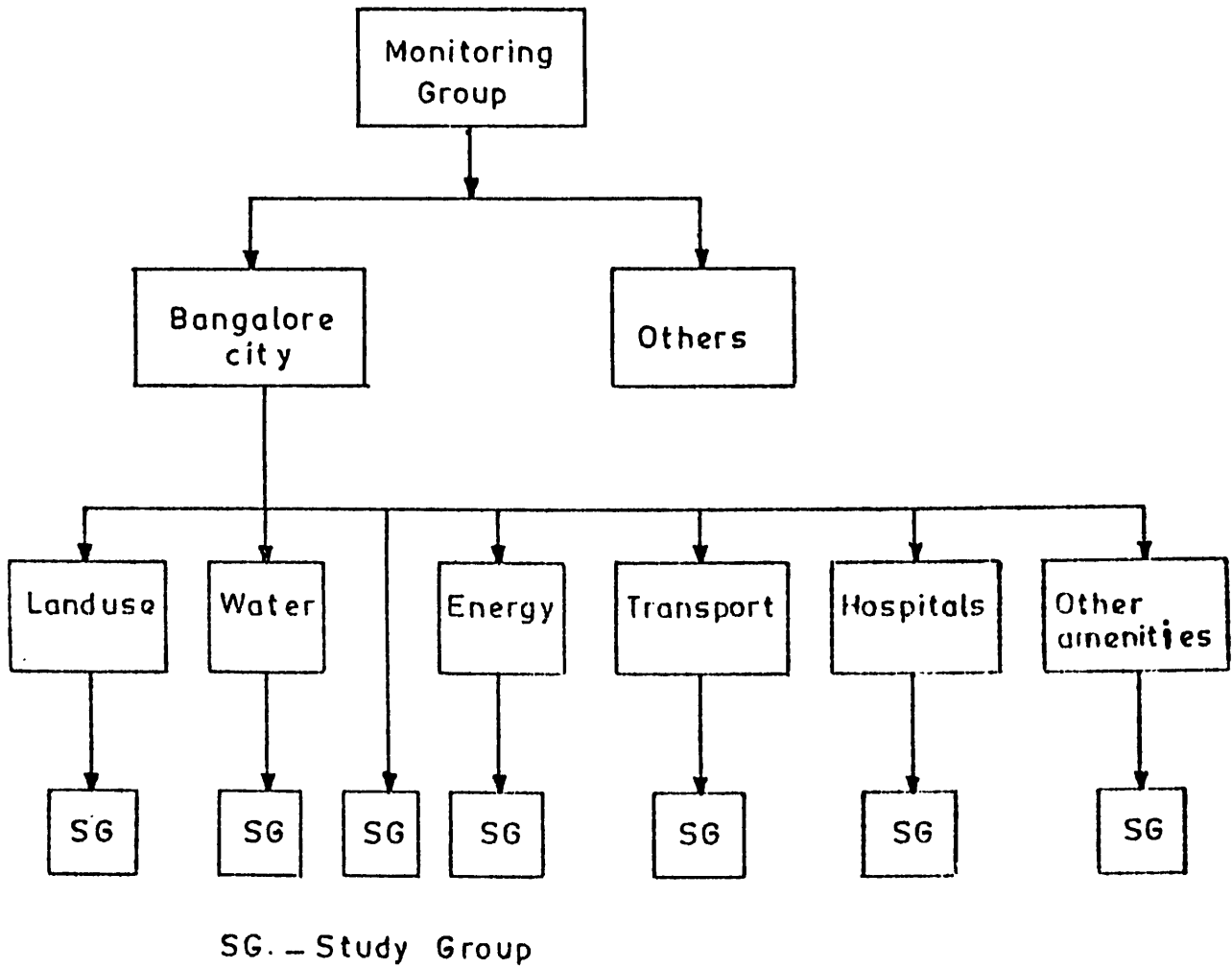

Fig.16- Structure of the monitoring group

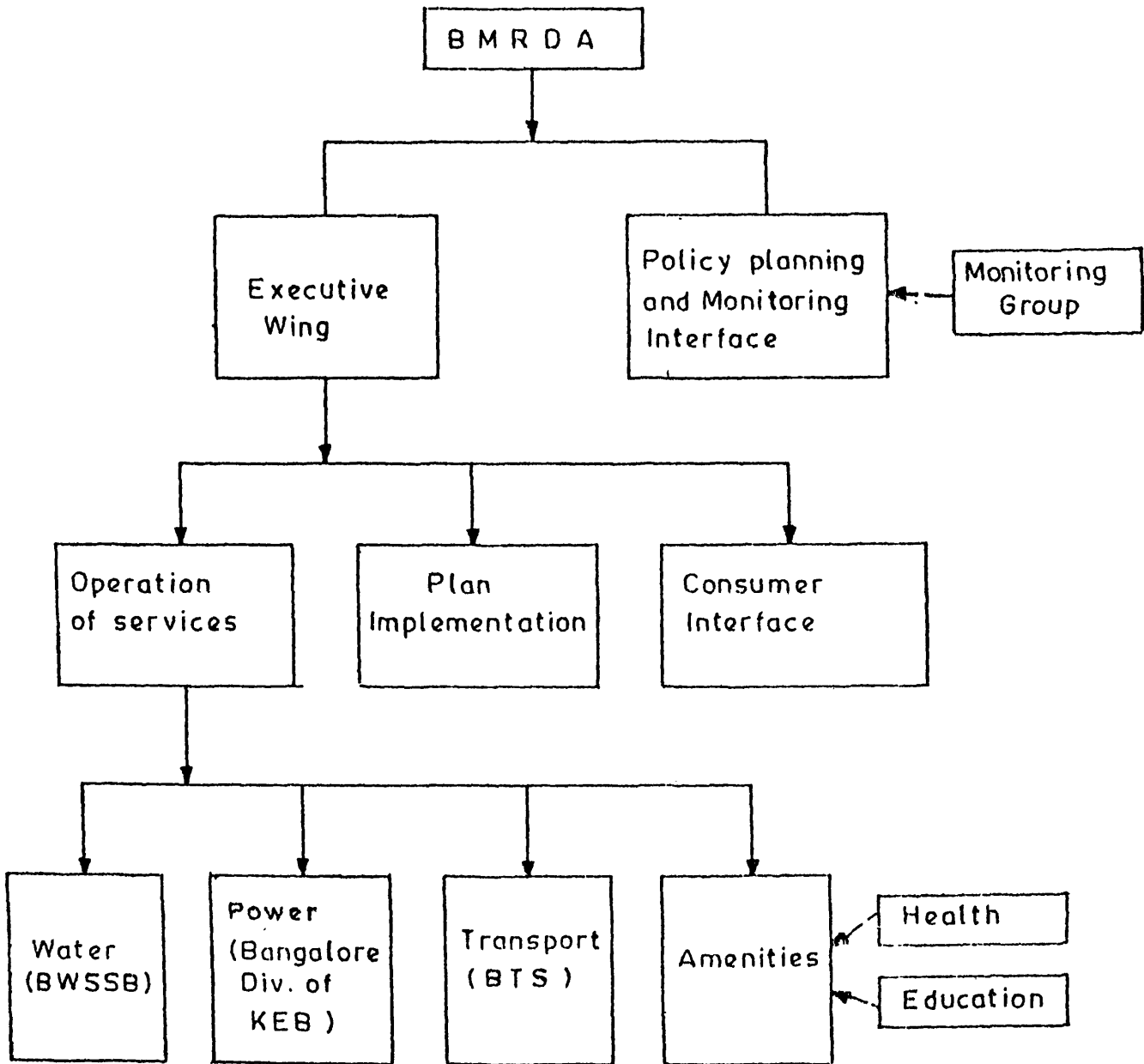

Fig.17 - Organizational structure for integration of services

## ESSAYS IN THE SERIES

### Vol. 1

1. Impact of Colonialism on the Economic Structure of Indian Cities: Bangalore 1800-1900  
—*Narendra Pani, Tara Ananda and Vinod Vyasulu*
2. The Industrial Structure of Bangalore  
—*Vinod Vyasulu*
3. Waste Recycle Industry in Bangalore  
—*Abdul Aziz*

### Vol. 2

1. A Study of the Climate of Bangalore  
—*A. Mani*
2. Slumming of a Metropolis  
—*H. Ramachandran*
3. Mosquito Control in Bangalore City  
—*T. Ramachandra Rao*
4. A Study on Corporation of the City of Bangalore  
—*M. Nageshwara Rao*

### Vol. 3

1. Transportation in Bangalore-I  
—*M. S. V. Rao*
2. Transportation in Bangalore-II  
—*N. Murali Mohan*
3. The Energy Sector of the Metropolis of Bangalore  
—*Amulya Kumar N. Reddy*

### Vol. 4

1. The Food Supply System of Bangalore  
—*Sukumar Muralidharan*
2. Supply, Distribution and Consumption of Milk in Bangalore  
—*Thomas P. Benjamin*
3. A Study of Elementary Education in Bangalore City  
—*S. Nayana Tara*
4. Water Supply to Bangalore City  
—*D. K. Subramanian*